



Towing a recreational trailer

What you need to know

towing a recreational trailer

what you need to know

© 2022, Insurance Corporation of British Columbia

All rights reserved. No part of this publication may be reproduced, stored or transmitted in any form, whether electronic, mechanical, photocopied or otherwise, without the prior written consent of the Insurance Corporation of British Columbia (ICBC). Applications for ICBC's written consent should be made to ICBC, 151 West Esplanade, North Vancouver, B.C. V7M 3H9.

Notwithstanding the foregoing paragraph, it is permissible to download and/or print one copy of this publication for personal use only.

This publication was formerly titled *Towing a Fifth Wheel Recreational Trailer*.

Statement of Limitation

ICBC has prepared *Towing a Recreational Trailer* to assist individuals studying for a British Columbia driving licence with a house trailer endorsement. *Towing a Recreational Trailer* is not intended to take the place of professional training and ICBC does not make any representation or warranty that any individual who studies *Towing a Recreational Trailer* will be successful in obtaining the desired licence. ICBC is not responsible for any consequences that may result from the use of *Towing a Recreational Trailer*.

Throughout this guide, references are made to acts and regulations that govern driving in British Columbia. This guide reflects the law in British Columbia as set out in these acts and regulations as of September 1, 2013. These references are written in plain language to help you understand their impact on individual drivers. In the event of a difference between the material included in *Towing a Recreational Trailer* and any of these acts or regulations, the acts and regulations shall apply.

contents

	Identification (ID)	F
Chapter 1	introduction	1
	Driver licensing requirements for towing a recreational trailer	3
	Towing an RV of less than 4,600 kg	3
	Trailer weight	3
	Towing an RV of more than 4,600 kg	3
	How to apply for a house trailer endorsement	4
	How to apply for a heavy trailer endorsement	4
Chapter 2	before you tow.....	5
	The towing vehicle	5
	Size.....	5
	Towing and weight capacity.....	5
	Vehicle requirements.....	6
	Engine.....	6
	Transmission	6
	Cooling system.....	6
	Axles and suspension.....	6
	Power brakes and power steering	6
	Electrical system	6
	Wheels and tires.....	6
	Tire wear.....	7
	Tire problems	8
	Mirrors.....	8
	The trailer to be towed.....	8
	The trailer connection	9
	Fifth wheel assembly.....	9
	Mounting the fifth wheel	9
	Ball and hitch connection.....	10
	Mounting a ball and hitch trailer connection.....	10
	Trailer brakes and brake controls	10
	Putting them together	11
Chapter 3	pre-trip inspection	13
	Before you begin	13
	What to look for	14

	Front of truck and under hood.....	14
	In passenger compartment.....	14
	Circle check for lights.....	15
	Mechanical circle check.....	16
	Left side of truck.....	16
	Left side of trailer.....	17
	Rear of trailer.....	17
	Inside of trailer.....	17
	Right side of trailer.....	17
	Right side of truck.....	18
	Brake response, tug and steering wheel slack tests.....	19
Chapter 4	driving an RV combination.....	21
	Power to move and power to stop.....	21
	Stopping distance and stopping time.....	21
	Speed and weight facts.....	22
	Braking and acceleration.....	23
	Braking.....	23
	Icy roads.....	23
	Anti-lock braking systems.....	24
	Downgrades.....	24
	Water on roadways.....	25
	Traffic.....	25
	Driving slower than the flow.....	25
	Tailgaters.....	25
	Stopped vehicles with flashing lights.....	26
	Construction zones.....	26
	Danger zones.....	26
	Turns and other manoeuvres.....	27
	Turning radius.....	27
	Off track.....	28
	Curves and turns.....	28
	Curves.....	29
	Clearance.....	29
	Narrow bridges.....	29
	Turning right.....	29
	Sharp right turns.....	29
	Turning left.....	30
	Seeing and being seen.....	30
	Using your mirrors.....	31
	Looking ahead.....	31
	Lane use.....	31

Passing and being passed	31
Turbulence.....	31
Choosing your route	32
Intersections.....	32
Traffic circles and roundabouts	33
Traffic circles	33
Roundabouts	33
Alleys, lanes and side roads	35
Railway crossings.....	35
Controlled and uncontrolled crossings.....	35
Acts of nature	36
Night Driving	36
Animals on the road.....	36
Coupling	37
Uncoupling	38
Parking.....	39
Backing up.....	39
Disabled vehicles.....	40
Personal safety.....	40
Carbon monoxide poisoning	40
Seatbelts.....	40
Airbags and head restraints	41
Cellphones and other devices.....	41
Impairment.....	42
Prescribed and over-the-counter drugs	42
Penalties for impaired driving	42
Criminal Code penalties.....	43
Graduated Licensing Program	43
Other costs of impaired driving	43
Vehicle impoundment	44
Fatigue.....	44
Emotions.....	44
Chapter 5 recreational trailer safety.....	45
Passengers	45
Loading your trailer.....	45
Propane	45
Safety equipment.....	45
Fire.....	45
Firefighting.....	46
Fire extinguishers	46
Before leaving a campground.....	47

	Storing your recreational trailer	47
	Maintaining your RV trailer combination	48
Chapter 6	signs, signals and road markings	49
	Signs	49
	Regulatory signs	50
	School, playground and crosswalk signs.....	51
	Lane use signs	51
	Turn control signs	52
	Parking signs.....	52
	Reserved lane signs.....	52
	Warning signs	53
	Object markers	54
	Construction signs.....	55
	Information and destination signs.....	55
	Railway signs.....	56
	Signals.....	56
	Lane control signals.....	56
	Traffic lights.....	57
	Road markings.....	58
	Yellow lines	58
	White lines	59
	Reserved lane markings	60
	Other markings.....	60
	Summary	61
	Review questions.....	61
	Definitions	62
	More information	62

introduction

fast fact

You may only tow one trailer for recreational purposes.

- A motorhome may tow a car (a tow dolly may be used) or a trailer.
- A truck towing an RV trailer may not tow any additional trailers.

To tow a recreational trailer safely, you'll need to know:

- how to select a towing vehicle capable of towing the recreational trailer
- how to select a recreational trailer and match it to the towing vehicle
- how a fifth wheel or ball and hitch connector works and how to choose one
- how to identify the parts of a trailer hitch
- how to couple and uncouple the truck and trailer
- how to conduct a pre-trip inspection of a recreational trailer combination
- how towing a large recreational trailer affects the handling and control of your vehicle
- how to drive a recreational combination safely.

This guide contains the basic information you need to know to drive while towing a recreational trailer.

It's also the study guide for the tests you'll need to pass in order to obtain a house trailer endorsement to operate heavy recreational house trailers over 4,600 kg.

While this guide focuses primarily on large fifth wheel RV trailers, it contains helpful information about towing a recreational trailer of any size or weight.

1

driver licensing requirements for towing a recreational trailer

fast fact

Few recreational trailers exceed 4,600 kg.

Most that exceed 4,600 kg are over nine metres (28 feet) in length. If you aren't sure of the weight of your RV trailer, take it to a weigh scale and have it weighed.

Most fifth wheel RV combinations don't have air brakes.

warning!

It is your responsibility to ensure you have the appropriate driver's licence and driving skills for the trailer you're towing. If you don't have the proper licence, you may be in breach of your insurance policy in the event of a crash. Your insurance claim may be denied, including claims for your own injuries, or damage that you might cause to your vehicle, or to other people or property. You may then be responsible for paying these costs.

Need more information?
Call 1-800-950-1498 or go to icbc.com.

Towing an RV of less than 4,600 kg

Most recreational trailers weigh less than 4,600 kg, and may be driven by a driver with a Class 5 or 7 passenger car driver's licence. An air brake endorsement is required if either the truck or trailer has air brakes.

Trailer weight

The class of driver's licence or licence endorsement you need to tow a trailer depends on its weight.

For driver licensing purposes, trailer weight means its actual weight at the time it is being towed. For example, your RV trailer may weigh 4,000 kg when sitting empty in your driveway and not connected to your pickup truck. You may tow the trailer empty with a Class 5 or 7 driver's licence because it doesn't exceed 4,600 kg. But when it's equipped with furniture, stored water, food and other items, the trailer will weigh more. A Class 5 or 7 driver's licence doesn't allow you to tow the trailer if it weighs over 4,600 kg.

Towing an RV of more than 4,600 kg

If you want to tow an RV that weighs more than 4,600 kg and neither the recreational trailer nor your truck has air brakes, you need:

- a Class 1, 2 or 3 driver's licence, or
- a Class 4 or 5 driver's licence with a heavy trailer endorsement (code 20), or
- a Class 4 or 5 driver's licence with a house trailer endorsement (code 07).

Note: The code 07 house trailer endorsement permits towing house trailers only. Other types of trailers over 4,600 kg, such as horse/house trailers (trailers with living quarters for people along with space to carry horses), boat trailers, horse trailers, utility trailers, etc. can't be operated with a house trailer endorsement.

To get a heavy trailer endorsement (code 20), you need to:

- pass a Class 3 knowledge test,
- meet commercial driver vision and medical standards, and
- pass a Class 3 road test while towing a trailer weighing more than 4,600 kg.

To get a house trailer endorsement (code 07), you need to:

- pass a recreational trailer knowledge test,
- meet driver vision and medical standards, and
- pass a road test while towing a recreational house trailer weighing more than 4,600 kg.

RV “toy” haulers?

A “toy” hauler is a towable RV combining living space with a mobile garage. The garage space can be used to carry motorcycles, ATVs and other “toys,” often with the rear panel opening like a drawbridge to create a loading ramp. Toy haulers are excellent options for weekend snowmobiling trips or taking personal watercraft to the lake. Toy haulers are available in trailer and fifth wheel configurations. You can haul this trailer (if more than 4,600 kg) with your Class 4 or 5 licence, as long as you have a house trailer endorsement (code 07).

fast fact

It’s your responsibility to ensure that your vehicle is properly insured for use during your road test. Check with your ICBC Autoplan broker if you have any questions about your coverage.

If you want to tow an RV that weighs more than 4,600 kg and either the recreational trailer or your truck has air brakes, you need a Class 1 driver’s licence with an air brake endorsement.

How to apply for a house trailer endorsement

1. Study this guide.
2. Apply for a learner’s licence at a driver licensing office. You’ll need to:
 - present one piece of primary and one piece of secondary identification (acceptable proofs of identification on the inside back cover).
 - pay the knowledge test fee
 - take the knowledge and road signs test
 - have your vision checked and answer questions relating to your medical health. You must disclose any known medical conditions.
3. You’ll receive your learner’s licence after successfully completing all of the above, unless you have a medical condition that requires pre-approval. A learner’s licence is valid for one year.
4. Practise with an appropriately licensed driver and/or attend a driver training school.
5. When you’re ready, phone to schedule your road test. In Metro Vancouver phone 604-982-2250; in Victoria phone 250-978-8300; other areas can phone toll-free at 1-800-950-1498.
6. Take your road test, which includes a pre-trip inspection test of your truck and recreational trailer combination.
Note: You need to bring the same identification you used to apply for your learner’s licence (Step 2) and the fee for your test.
7. You’ll receive a temporary licence after you successfully complete all your licensing tests and pay the fee for your new driver’s licence.
8. You’ll receive your photo licence in the mail once we confirm that you meet the required medical standards.

How to apply for a heavy trailer endorsement

For details on obtaining a Class 1, 2 or 3 driver’s licence or a heavy trailer endorsement, refer to *Driving Commercial Vehicles* (available at all driver licensing offices and on icbc.com).

definitions

Towing capacity is the maximum weight that a vehicle is capable of towing.

Gross Vehicle Weight Rating (GVWR) is the maximum weight of the vehicle plus its passengers and cargo, and includes the portion of the trailer weight that is placed over the towing vehicle (pin weight).

Load capacity is the weight of the driver, passengers, fuel, cargo and vehicle options, including the portion of the trailer weight that is placed over the towing vehicle.



The towing vehicle

Before you buy or tow an RV trailer, make sure that you have a truck that is capable of towing it. Towing a trailer puts extra demands on the truck and affects handling, braking and acceleration.

Size

Compare the size of the truck that you are going to use to tow the trailer to the size of the trailer. Even if a compact pickup truck is capable of handling the weight of an RV trailer, its narrow width compared to the wider trailer width may affect vision to the rear. If you have a smaller truck you may want to consider side mirror extenders to improve your visibility. Narrower trailers are available for use with compact pickup trucks. It's best to select a full-size pickup truck to tow a large recreational trailer.

fast fact

Exceeding the load capacity, GVWR or towing capacity is unsafe and may void any warranty on the vehicle.

Motor Vehicle Act Regulations prohibit the operation of vehicles that are unsafely or improperly loaded, or that exceed weight ratings.

Towing and weight capacity

You need to know the truck's:

- towing capacity rating,
- GVWR, and
- load capacity.

These are usually listed in the owner's manual and on a plate or decal on the vehicle.

Make sure that the truck's towing capacity, GVWR and load capacity are rated for the load to be carried and the trailer you want to tow.

Vehicle requirements

Most manufacturers have trailer towing packages which include some or all of the following options. Make sure your truck is equipped for the trailer you intend to tow.

Engine

Diesel engines usually make more torque, which is what is needed for towing a large trailer, and may also be more fuel-efficient than gasoline engines.

Transmission

A heavy-duty transmission capable of coping with towing a trailer is needed. You'll need to check your transmission fluid regularly.

Cooling system

The added weight of the trailer increases the engine and transmission temperatures so your truck may need a heavy-duty radiator, along with an oil cooler and transmission cooler, in order to tow a large trailer safely.

Axles and suspension

Heavy duty springs and shock absorbers are needed to handle the added weight of the trailer. Load leveling suspension will help keep sufficient weight over the steering axle by helping keep the truck level. The drive axle gear ratio also needs to be appropriate to tow a trailer. The Gross Axle Weight Rating (GAWR) of each axle also needs to be able to handle the load.

Power brakes and power steering

These will reduce driver fatigue and make it easier to handle your RV combination.

Electrical system

A heavy-duty battery and alternator may be needed for additional lighting, along with a special wiring harness to connect to the trailer lights. Recreational trailers usually have electrically operated brakes, so a special controller is needed in the pickup truck to operate the trailer brakes. Some new pickup trucks have an integrated trailer brake controller unit but with others, a special controller needs to be installed.

Wheels and tires

Manufacturers put a load rating on their tires. Make sure that the maximum load rating stamped on the tire is sufficient for the load that it will carry. Don't let the weight of your vehicle and load exceed the rating for any individual tire or any group of tires on a single axle.

Check and adjust tire pressure when tires are cool. Use a tire pressure gauge. If a tire has the correct pressure when it's cool, it will generate a normal amount of heat during use. This heat will cause the pressure within the tire to increase and reduce the amount of wall flexing. When wall flexing is kept under control, heat build up is also controlled.

definition

Gross Axle Weight Rating (GAWR) is the maximum weight that can be placed over an axle according to manufacturer's engineering standards.

driving tip

Make sure the tires on both the truck and the trailer are rated for the type and weight of the vehicle including its load.

Put proper truck tires on the truck and trailer tires on the trailer.

fast fact

When the amount of contact between the tire and the road surface is reduced, steering control is also reduced.

fast fact

Rust streaks on the rim may indicate a loose lug nut or cracks in the rim.

Various types of tire wear patterns.

Ensure the tread depth on your tires conforms to the standards set out in the Motor Vehicle Act Regulations.

Tire wear

Operating your vehicle with improperly inflated tires will cause your tires to wear out more quickly. It may also reduce the amount of steering control you have.

Overinflating a tire causes excess wear in the centre part of its tread. An overinflated tire has less tread surface in contact with the road surface.

Less contact between your tire and the road means less traction.

Underinflating a tire causes excess wear on the outer edges of its tread. An underinflated tire builds heat more quickly which may result in a tire blowout. In wet conditions, an underinflated tire will not squeeze the water out from between the tire and the road as well as a properly inflated tire. A tire that's underinflated has a greater chance of riding on a film of water (hydroplaning).

Some new vehicles are equipped with a Tire Pressure Monitoring System (TPMS) to warn the driver if tire pressure is getting low. However, TPMS doesn't replace the need to periodically check and adjust tire pressure.

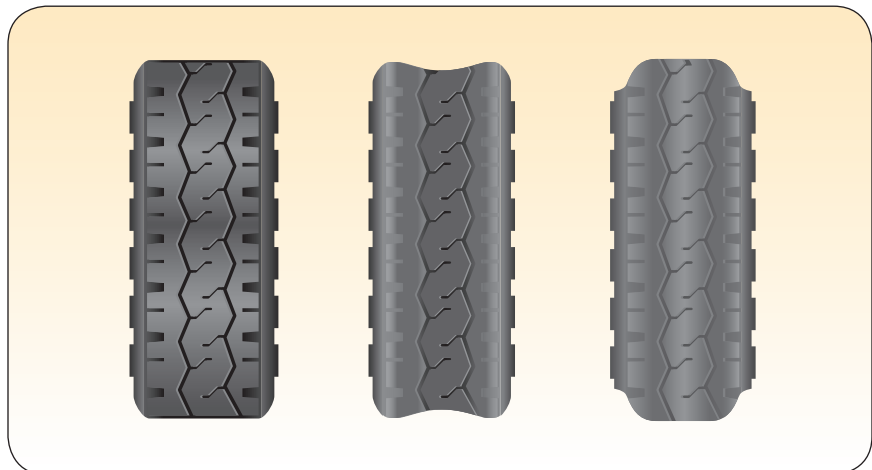

Tire problems

Here are some problems to look for on most tires:

- too much or too little air pressure — use a gauge to ensure correct pressure
- tire wear — check for tread depth and tread recap separation
- cuts, abrasions, exploding cord, sidewall separation or bulges or cracks
- tires in contact with each other or tires in contact with any part of the vehicle
- cracked or leaking valve stems
- different sizes or radial and bias-ply tires being used on the same axle — these can be mixed on the same vehicle but not on the same axle (not a recommended practice).

Note: If you change a tire, stop after a short while and check to be certain the wheel nuts are tight.

Mirrors

You may need to install wide-angle or accessory extended mirrors to get a good view around the trailer you will be towing. Your side mirrors should be adjusted to show the trailer in the first three centimetres (one inch) of the mirror with the rest showing the space behind and beside your vehicles. Your mirrors should allow you to see at least 200 metres behind your vehicle. It's a good idea to add a convex mirror below each outside mirror. This will help you to see the tracking of your trailer wheels and vehicles that may be in your blind spots, especially on your right hand side.

driving tip

Remember that with convex mirrors, objects may be closer than they appear. Don't rely on convex mirrors when judging the distance between your vehicle and traffic behind you.

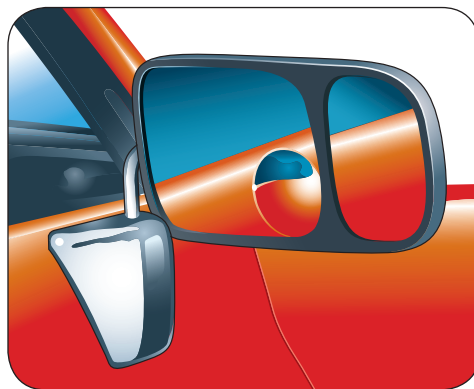

The trailer to be towed

You need to know the Gross Vehicle Weight of the trailer including its load, and how much of that weight is on the trailer hitch, to calculate if the truck is capable of towing the trailer.

There is usually a plate or decal on the trailer indicating the GVWR. This is the manufacturer's recommended maximum weight of the trailer and its load. Most RVs carry a lot of water for washing, cooking and sanitation, along with furniture, food and other supplies. This weight needs to be included when determining if the actual trailer weight is within its GVWR, and if the truck has the towing capacity required for the trailer.

fast fact

The pin weight or hitch weight should be 15 to 25 per cent of the fifth wheel trailer's actual loaded weight.

fast fact

Your fifth wheel should be rated to tow 20 per cent more than your trailer's weight. For example, if your fifth wheel RV weighs 5,000 kg, select a fifth wheel that is rated for at least 6,000 kg.

driving tip

Make sure the fifth wheel is securely fastened to the truck's frame, not just to the pickup bed, or there is a risk it may come loose from the truck. If your truck has a bed liner, this will need to be removed in the area where the fifth wheel is placed.

You also need to determine how much of this weight will be on the truck. This is called the pin weight or hitch weight. Too little pin weight or hitch weight can cause the trailer to sway. Too much weight can cause steering problems, as there may not be enough weight on the truck's front axle for proper control. You can measure these weights at a public weigh scale.

The trailer connection

A ball and hitch or fifth wheel is used to connect the trailer to the towing vehicle.

Smaller lighter trailers usually use a ball and hitch connection; larger heavier ones use a fifth wheel.

Fifth wheel assembly

The basic components of the fifth wheel assembly mounted in the pickup truck bed are:

- fifth wheel plate — this includes the hitch plate, plate jaws and handle
- locking device — this holds the plate jaws closed
- side rails — these support the fifth wheel plate.

The basic components of the fifth wheel assembly on the trailer are:

- kingpin — this is the pin that attaches to the fifth wheel hitch on the pickup truck
- pin box — this is attached to the bottom front section of the trailer frame (The kingpin is attached to the bottom of the pin box.).

Mounting the fifth wheel

Consult a professional to help select and install the right fifth wheel assembly for your combination. Make sure there is clearance between the back of the truck cab and the front of the trailer, between the bottom of the trailer and the pickup box, and between trailer sides and the pickup box. This leaves space for the trailer to turn without striking the truck, and for movement between the truck and trailer when going over bumps or starting to go up or down steep hills.

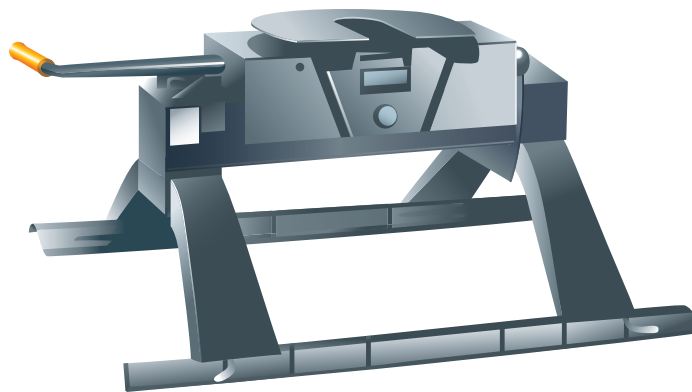

fast fact

The fifth wheel should be mounted over, or ahead of, the rear axle.

It should never be mounted behind the rear axle.

fast fact

When fastening the chains on a ball and hitch connection, cross the chains over each other, under the ball and hitch.

driving tip

Consult a professional to help select and install the trailer brake connections and controls for your RV combination.

driving tip

An emergency breakaway device is meant for emergency use only. **Do not** use it as a parking brake.

A fifth wheel hitch should never be mounted behind the rear axle of the truck, which would reduce the percentage of weight over the truck's front axle and reduce steering control. You could damage both truck and trailer, and create a hazard for other road users.

Ball and hitch connection

The basic components of a ball and hitch connection are:

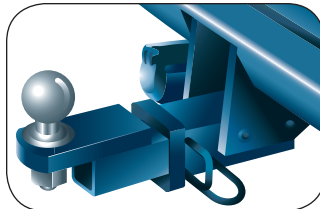

- the ball hook mounted on the truck

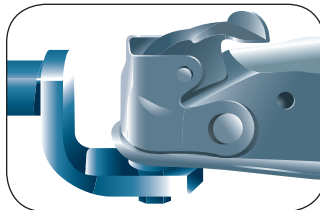

- the hitch on the trailer to connect to the ball on the truck.

Safety chains or cables are also required to connect the trailer to the truck in case of hitch failure.

A load equalizing hitch assembly is often used with heavier trailers.

There are various classes of hitches, each designed to handle a certain range of weight.

Mounting a ball and hitch trailer connection

Consult a professional to help select and install the right type of assembly for your combination. Make sure there is enough height to clear bumps in the road and areas that you will back the unit into.

The added weight of the trailer may load down the rear of the truck, reducing the percentage of weight over the truck's front axle, resulting in reduced steering control. Load leveling hitches can help to compensate for the added weight of the trailer.

Trailer brakes and brake controls

Most RV trailers have either electric brakes or hydraulic surge brakes. Surge brakes are not allowed on trailers over 2,800 kg GVWR. As well, recreational trailers have an emergency breakaway device that will activate the trailer brakes if the trailer comes adrift from the truck.

Some new trucks are equipped with an integrated trailer brake controller, but in most cases special controls need to be added so you can activate the trailer brakes with the truck's brakes.

Most electric brake controllers are dash-mounted and have a manual override button to allow the trailer brakes to be operated without operating the tow vehicle braking system if needed.

Follow the manufacturer's instructions for use of the brake controller, including adjusting the RV trailer's brake sensitivity relative to that of your truck's brakes and for various driving conditions, such as driving in the city or driving on highways. As well, follow the manufacturer's instructions for inspecting and testing trailer brake response as part of a pre-trip inspection.

fast fact

If your truck has an anti-lock braking system (ABS), only certain types of brake controllers can be used. They must be carefully installed to ensure that the ABS system will still function properly.

driving tip

The weight of the trailer may load down the rear of the truck, so the headlights aim higher than they did before. Check the headlight aim when you have the trailer attached to the truck, and adjust as needed.

Putting them together

You may have a pickup truck with a towing capacity of 5,500 kg and a load capacity of 1,500 kg, and a fifth wheel RV weighing 5,000 kg fully loaded with a pin weight of 750 kg.

In this example, the gross weight of the trailer is within the towing capacity of the truck, and the pin weight is within the truck's 1,500 kg load capacity.

But after you subtract the pin weight from the truck's load capacity, only 750 kg of load capacity remains to accommodate the total weight of all people, fuel and cargo in the truck. Otherwise, the truck's load capacity and GVWR will be exceeded.

Exceeding your truck's load capacity and GVWR will significantly affect your vehicle handling and braking, jeopardizing the safety of all road users. It is also illegal, unsafe and can reduce its service life. Police may also ticket you for operating an overweight vehicle. If you are involved in a crash and the overweight problem contributed to the accident, you could be found partially or totally responsible for the crash.



3

pre-trip inspection

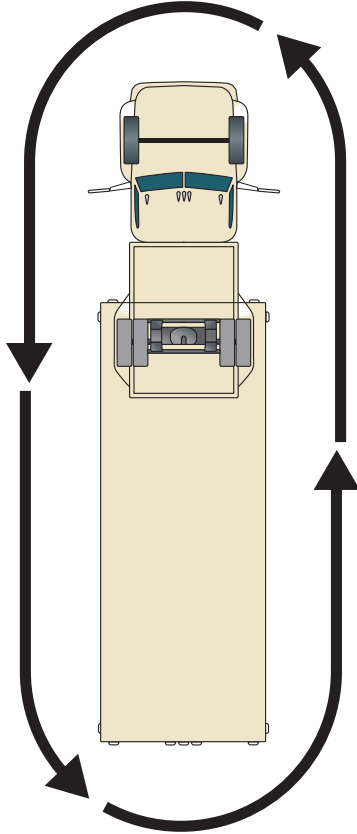

A pre-trip inspection can make the difference between a safe trip and one that ends in disaster. The inspection is to look for possible safety defects and potential mechanical problems that could range from costly repairs and delays while on the road to collisions, injuries or even death.

You should conduct a full pre-trip inspection daily to make sure that your truck and trailer are safe for operation. With a bit of practice, a full pre-trip inspection doesn't take long to complete. When travelling, you should do a brief inspection of your truck and trailer every time you stop.

The pre-trip inspection begins with checking under the hood, then getting into the truck to check gauges, etc., walking around the truck and trailer to check lights and certain mechanical components. The final step is to pull ahead slowly to check for brake and steering response.

As part of your road test, you will be tested on your ability to complete a pre-trip inspection. You should assume that the vehicle has not been operated on the day of your test and that a pre-trip inspection has not been done. During the test, point to and physically check the items you are inspecting. At the same time, tell the examiner what you are looking for. For example, *"I am checking the four-way flashers to see if they work, and are securely mounted, that the lenses are clean, and not cracked and that the colour is correct."*

Before you begin

- Park your vehicle safely away from traffic on a level surface.
- Set parking brake. Place transmission in Park (or low gear if manual transmission).
- Shut off the engine.
- Block the trailer wheels for added safety.
- Do a circle check to conduct your inspection, walking in a counterclockwise direction to face oncoming traffic.
- During your circle check, you will need to return to the driver's seat several times to turn on (and then turn off) lights to check that they are working properly. Be particularly cautious when you are walking with your back to traffic.

What to look for

1. Front of truck and under hood

As you approach, look under the vehicle for leaks. Check the following:

<input type="checkbox"/> Licence plate	<ul style="list-style-type: none"> • check for licence plate
<input type="checkbox"/> Fluids	<p>Check fluid levels and condition (for example, colour, smell) including:</p> <ul style="list-style-type: none"> • engine oil • engine coolant • power steering fluid • brake fluid • windshield washer fluid • transmission fluid
<input type="checkbox"/> Belts	<ul style="list-style-type: none"> • ensure any drive belts have good tension and no cracks, frayed cord or missing teeth
<input type="checkbox"/> Hoses	<ul style="list-style-type: none"> • ensure they are secure with no kinks, leaks, cuts, abrasions or cracks
<input type="checkbox"/> Battery	<ul style="list-style-type: none"> • check for visible corrosion or leaks • terminal connections are secure • battery is securely mounted • battery fluid level (if applicable—dry/spiral/grid cell batteries do not have fluid.)
<input type="checkbox"/> Engine compartment	<ul style="list-style-type: none"> • check for fuel, oil or coolant leaks

Close and secure hood.

2. In passenger compartment

<input type="checkbox"/> Seats, seatbelts	<ul style="list-style-type: none"> • check driver's seat is adjusted for you • seatbelt is in working order • check that all seatbelts are in good condition and work well • seats and passenger compartment is clean
<input type="checkbox"/> Mirrors	<ul style="list-style-type: none"> • ensure they are adjusted for you and are clean and free of cracks
<input type="checkbox"/> Windows/windshield	<ul style="list-style-type: none"> • ensure they are clean and free of cracks • check that windows open and close
<input type="checkbox"/> Documentation	<ul style="list-style-type: none"> • ensure that vehicle licence, registration and insurance for both the truck and trailer are up-to-date

Start engine, check the following:

<input type="checkbox"/> Instrument panel	<p>Ensure that all gauges and warning lights are working properly, and that they respond properly as the engine warms up:</p> <ul style="list-style-type: none"> • charge rate indicator or gauge works properly and charge is good • oil pressure indicator or gauge indicates normal pressure soon after engine starts • coolant temperature indicator or gauge rises to normal operating temperature — light should go off after engine starts • fuel gauge indicates sufficient fuel • instrument lights work
<input type="checkbox"/> Windshield wipers/washers	<ul style="list-style-type: none"> • ensure wipers and washers work
<input type="checkbox"/> Heater/defroster	<ul style="list-style-type: none"> • ensure heater and defroster controls work, including the fan in the heater and defroster positions
<input type="checkbox"/> Interior lights	<ul style="list-style-type: none"> • ensure they work
<input type="checkbox"/> Four-way flashers	<ul style="list-style-type: none"> • check that both indicators on dashboard work (the exterior lights will be checked later as part of checking the turn signals)
<input type="checkbox"/> Horn	<ul style="list-style-type: none"> • ensure it works
<input type="checkbox"/> Engine noises	<ul style="list-style-type: none"> • listen for unusual sounds

3. Circle check for lights

Turn on left turn signal, low beam headlights and clearance lights.

- Conduct circle check by walking counterclockwise to face traffic. Be particularly cautious when you are walking with your back to traffic.

<input type="checkbox"/> Lights	<p>As you inspect the vehicle, check all lights:</p> <ul style="list-style-type: none"> • ensure they work • lenses are clean and not cracked
--	---

1. Check that left turn signals, low beam headlights, tail lights, licence plate lights and clearance lights are working.

Turn off left turn signal. Turn on high beam headlights and right turn signal.

2. Check that right turn signal and high beam headlights are working.
3. Check that brake lights are working.

Return to cab. Turn off lights. Turn off engine.

4. Mechanical circle check

Leave cab and begin circle check.

Left side of truck

<input type="checkbox"/> Mirrors	<ul style="list-style-type: none"> ensure they are securely attached
<input type="checkbox"/> Exhaust system (if accessible)	<ul style="list-style-type: none"> ensure it is in good condition no leaks mufflers and pipes securely fastened
<input type="checkbox"/> Fuel cap	<ul style="list-style-type: none"> ensure fuel cap is securely fastened
<input type="checkbox"/> Storage compartments	<ul style="list-style-type: none"> ensure compartments are securely fastened doors open and close properly contents are secure
<input type="checkbox"/> Body	<ul style="list-style-type: none"> check for body damage
<input type="checkbox"/> Fifth wheel connection	<ul style="list-style-type: none"> plate is flush to the trailer apron (no daylight is visible between fifth wheel and apron) fifth wheel is securely fastened to truck fifth wheel location allows sufficient space for trailer to turn without striking truck locking jaws are closed around trailer kingpin
<input type="checkbox"/> Other type of trailer connection	<ul style="list-style-type: none"> ensure pintle hitch or ball hitch is not worn locking mechanism is closed and secure chains or cables (if equipped) have no stress cracks or weld breaks and are securely attached to truck and trailer
<input type="checkbox"/> Suspension, axles, drive train and frame (if accessible)	<p>As you inspect the vehicle, check the suspension, axles, drive train and frame:</p> <ul style="list-style-type: none"> ensure there are no cracked, missing or broken springs or torsion bars no loose, missing or broken U-bolts if air suspension, no cracked, worn or inoperative airbags mounts are secure check for axle leaks check for bent or broken axles
<input type="checkbox"/> Tires/wheels	<p>As you inspect the vehicle, check all tires, wheels and mud flaps:</p> <ul style="list-style-type: none"> check tires for inflation, signs of bulges, sidewall separation, cuts to cord, exposed or frayed belts adequate tread depth tire wear is even duals are not touching and nothing is stuck between them check wheels for cracks, missing pieces, bends or rust streaks (may indicate loose wheel nuts) ensure wheel lugs and nuts are secure, not missing, broken or loose check that mud flaps are secure mud flaps do not rub tires
<input type="checkbox"/> Licence plate	<ul style="list-style-type: none"> check for rear licence plate and decal
<input type="checkbox"/> Tailgate, pickup bed	<ul style="list-style-type: none"> tailgate securely latched cargo in pickup bed secure
<input type="checkbox"/> Trailer line, emergency breakaway switch	<ul style="list-style-type: none"> ensure trailer line, connection and breakaway switch are securely attached check for kinks, cuts, abrasions or cracks

Left side of trailer

<input type="checkbox"/> Suspension and frame (if accessible)	<ul style="list-style-type: none"> • check trailer suspension and frame
<input type="checkbox"/> Tires/wheels/mud flaps	<ul style="list-style-type: none"> • check trailer wheels
<input type="checkbox"/> Trailer body	<ul style="list-style-type: none"> • check for body damage • front and rear stabilizers are raised • handles and locking pins are secure

Rear of trailer

<input type="checkbox"/> Exterior storage	<ul style="list-style-type: none"> • ensure that items attached or stored on the outside of the trailer (for example, bicycles, chairs) are secure and do not obscure lighting or licence plate • check that propane tanks are turned off
<input type="checkbox"/> Licence plate	<ul style="list-style-type: none"> • check for licence plate and valid decal

Inside of trailer

<input type="checkbox"/> Security	<ul style="list-style-type: none"> • check that there are no loose objects that could be a safety hazard when the trailer is in motion • if RV is equipped with slide-outs, check that they are closed and locked • check that propane appliances and pilot lights are turned off
--	--

Right side of trailer

<input type="checkbox"/> Suspension, axles and frame (if accessible)	<ul style="list-style-type: none"> • check trailer suspension, axles and frame
<input type="checkbox"/> Trailer side door(s), steps, water tanks	<ul style="list-style-type: none"> • ensure door is secure • steps are properly stored • tanks are shut off
<input type="checkbox"/> Tires/wheels/mud flaps	<ul style="list-style-type: none"> • check trailer wheels
<input type="checkbox"/> Trailer body	<ul style="list-style-type: none"> • check for body damage • front and rear stabilizers are raised • handles and locking pins are secure

Right side of truck

<input type="checkbox"/> Mirrors	<ul style="list-style-type: none"> • ensure they are securely attached
<input type="checkbox"/> Exhaust system (if accessible)	<ul style="list-style-type: none"> • ensure it is in good condition • no leaks • mufflers and pipes securely fastened
<input type="checkbox"/> Fuel cap	<ul style="list-style-type: none"> • ensure fuel cap is securely fastened
<input type="checkbox"/> Storage compartments	<ul style="list-style-type: none"> • ensure compartments are securely fastened • doors open and close properly • contents are secure
<input type="checkbox"/> Body	<ul style="list-style-type: none"> • check for body damage
<input type="checkbox"/> Fifth wheel connection	<ul style="list-style-type: none"> • plate is flush to the trailer apron (no daylight is visible between fifth wheel and apron) • ensure slider is locked and secure with sufficient space for trailer to turn without striking truck • locking jaws are closed around trailer kingpin
<input type="checkbox"/> Other type of trailer connection	<ul style="list-style-type: none"> • ensure pintle hitch or ball hitch is not worn • locking mechanism is closed and secure • chains or cables (if equipped) have no stress cracks or weld breaks and are securely attached to truck and trailer
<input type="checkbox"/> Suspension, axles and frame (if accessible)	<ul style="list-style-type: none"> • check truck rear suspension, axles and frame
<input type="checkbox"/> Tires/wheels/mud flaps	<ul style="list-style-type: none"> • check truck wheels
<input type="checkbox"/> Tailgate, pickup bed	<ul style="list-style-type: none"> • tailgate securely latched • cargo in pickup bed secure

Set parking brakes. Remove blocks by wheels.

5. Brake response, tug and steering wheel slack tests

Perform the following steps:

1. Start engine.
2. In low gear, gently tug against the parking brakes. The brakes should prevent the combination from moving.
3. Release the parking brakes.
4. Apply the trailer brakes. In low gear, gently tug against the trailer brakes. The trailer should resist moving with the truck. (This test checks that the units are securely coupled and that the trailer brakes are working.)
Note: If the truck has an integrated trailer brake controller, the trailer brakes may activate only if the trailer is moving at speeds of 25 km/h or more. In this case, use steps 9 and 10 to test the trailer brakes.
5. Release all brakes.
6. Move the vehicle ahead slowly and gently apply the foot brake to check brake response.
7. Set the parking brakes. Place transmission in low gear (Park if automatic transmission).
8. Exit the cab.
9. Disconnect the trailer electrical cable, then pull the pin from the trailer breakaway switch housing.
10. Check that the trailer brakes have applied by gently tugging against the trailer brakes in low gear. The trailer brakes should prevent the trailer from moving.
11. Reinstall the pin in the trailer breakaway switch housing and reconnect the trailer electrical cable.
12. Move the steering wheel to check for excessive slack or lash (play).

4

driving an RV combination

fast fact

Fuel-efficient driving techniques can improve fuel economy by up to 30 per cent. Fuel-efficient driving is also smart driving. By looking ahead, keeping good space margins and anticipating road hazards, you can avoid sudden stops and changes in speeds. These and other smart driving habits also save on fuel and maintenance costs.

For more smart ways to be fuel-efficient, go to the Natural Resources Canada Office of Energy Efficiency website at www.oeenrncan.gc.ca or call 1-800-387-2000.

definition

Driver's perception time
 + reaction time
 + braking time
 = total stopping time

fast fact

Total stopping distance or time depends on the ability of the brake linings or pads to produce friction, the brake drums to dissipate heat and the tires to grip the road. You should keep at least a five-second following distance between you and vehicle ahead of you when you are towing an RV.

Power to move and power to stop

A typical compact car weighs about 1,000 kg and has about 120 horsepower. It can accelerate to 100 km/h within about 200 metres and in less than 10 seconds.

A pickup truck and RV trailer may weigh 8,000 kg. Even though the truck may have a diesel engine producing over 300 horsepower, because of the weight of the combination and its load accelerating to 100 km/h may take 500 metres or more and require 30 seconds or more.

Now think about stopping this combination from 100 km/h. How much energy is needed to stop it? You would certainly want to stop it in a much shorter distance and time than it took to accelerate to 100 km/h. In an emergency, the rig might have to be braked to a stop in as little as seven seconds — about one-quarter of the time it took to reach 100 km/h.

To stop the vehicle in one-quarter of the time it took to accelerate would require a stopping force of four times the acceleration force — the equivalent of approximately 1,200 horsepower.

Reduce your speed in snow or ice. In extremely bad conditions, it may be safer to park your vehicle than to continue driving.

Stopping distance and stopping time

To stop a vehicle, you need to **see-think-do**. Total stopping distance is the distance your vehicle will travel from the moment you:

- **see** — a hazard
- **think** — decide to stop
- **do** — place your foot on the brake pedal until you stop.

This *distance* can also be expressed as the *time* it takes to stop.

When you see a problem ahead while driving, it will take you about three-quarters of a second of **see-think (perception time)** and another three-quarters of a second of **do (reaction time)**. Only then will your vehicle begin to slow.

Add to this the **braking time** — the time or distance the vehicle travels before it stops.

This is why it is so important to allow enough following distance.

- When driving a passenger car or light truck, use the two-second rule.
- When driving a motorhome or towing an RV trailer, you should be at least five seconds behind the vehicle ahead at highway speeds.

When conditions are anything less than ideal, such as when road or weather conditions are poor, increase the number of seconds and adjust your following distance.

You should keep at least a five-second following distance between you and the vehicle ahead of you when you are towing an RV.

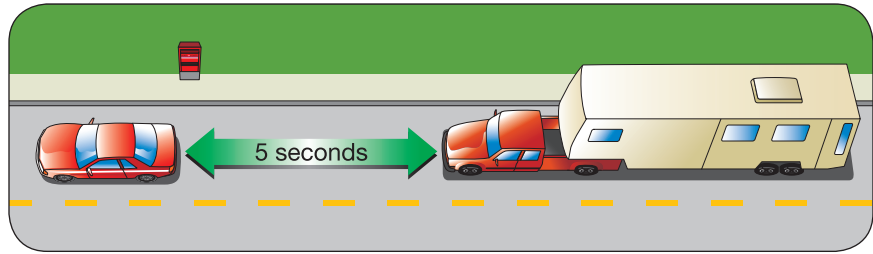

In the graphic above, as the car passed the mailbox, the RV driver began counting "one thousand and one, one thousand and two ... one thousand and five." That's five seconds.

If the mailbox was reached before the count is finished, the following distance is not enough — drop back, pick a new checkpoint and count again.

Speed and weight facts

Speed and weight affect the stopping power required to stop any vehicle, and how far it will travel before it stops. You need more stopping power whenever the speed you are travelling and/or the weight of your vehicle increases:

- 2 times vehicle speed requires 4 times the stopping power
- 2 times vehicle weight requires 2 times the stopping power
- 2 times vehicle speed and 2 times vehicle weight requires 8 times the stopping power.

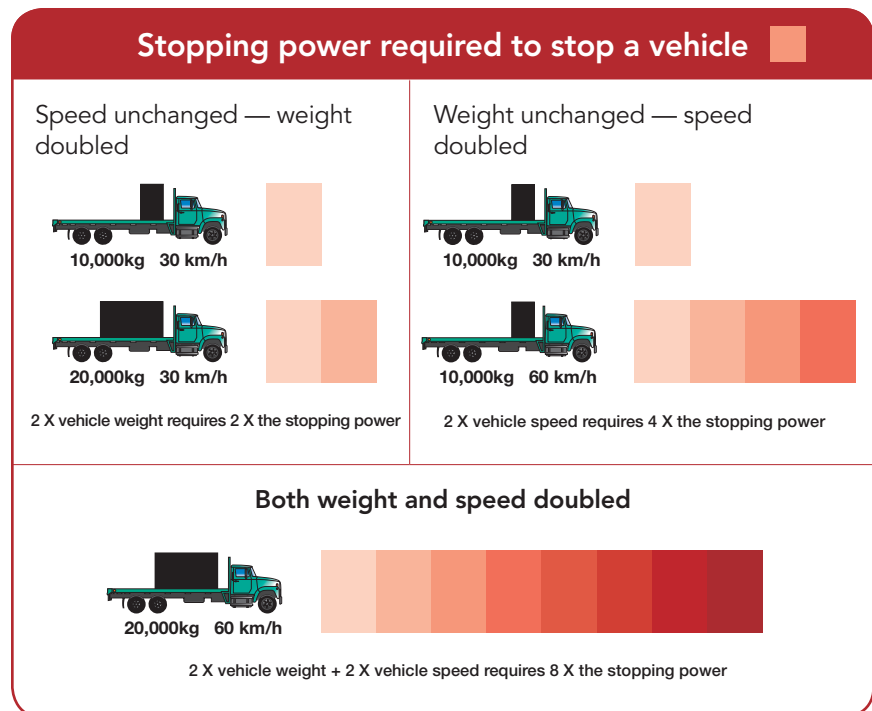

Braking and acceleration

Towing an RV causes extra strain on the truck's brakes, and it will take longer to stop when towing a trailer.

Towing an RV also results in slower acceleration.

Braking

Stopping your vehicle on a level roadway usually means squeezing gradually and firmly on the brake pedal with your foot. But, as the speed or weight of your vehicle or the degree of emergency increases, you may have to react more quickly.

Just before your vehicle comes to a full stop, reduce the pressure on the brake pedal. This will prevent your vehicle from jerking back. Practise stopping until you become familiar with how much pressure you need to ease off the brake to smoothly stop where you want.

Watch the driving technique of the driver ahead. If the driver in front of you is a tailgater, expect frequent panic stops. Professional drivers maintain a safe following distance and plan for gradual stops. By making your stops slowly, you give the driver behind you plenty of notice that you are reducing your speed.

Heavy RV trailers have longer stopping times and distances. To stop safely, you must ensure that your brakes are well maintained, your load is balanced and your tires are in good condition. You should also be certain that your tires are properly inflated.

To ensure a smooth, controlled stop every time:

- travel at a speed that allows you to see a safe distance ahead
- maintain a safe following time or distance
- use good braking skills

Icy roads

To stop on icy roads, use extremely light pressure on the brake to control your vehicle's speed. This will help prevent the wheels from locking up. A slowly revolving wheel on an icy surface will be more effective than a locked wheel skidding on an icy surface. ABS equipped vehicles require a different technique for braking on an icy road surface, as explained later in this chapter.

Don't let snow and ice build up in the rear of the truck. The added weight of the snow and its build-up can interfere with the clearance between the truck and the RV, affecting steering and handling.

Using chains on icy roads is a good idea. Make sure you're familiar with how to mount chains on tires — practise mounting them before you find yourself in conditions where you need to put them on your vehicle.

Make certain tire chains are properly sized for your tires and tightly mounted (do not deflate tires to install tire chains). Remember to stop after driving approximately 400 metres to check tire chain tightness. Reduce speed when driving with tire chains.

Reduce your speed in snow or ice. In extremely bad conditions, it may be safer to park your vehicle than to continue driving.

Anti-lock braking systems

Contrary to what many people believe, anti-lock braking systems (ABS) don't allow you to drive faster and they don't always allow you to stop sooner. In fact, on some surfaces such as gravel, the braking distance needed with ABS may be longer.

Anti-lock brakes can help prevent wheel lock-up on surfaces where conventional brakes usually lock up — including surfaces that may be slippery because of water, ice, wet leaves, grease or spilled fluids. This means you can brake hard without skidding and losing steering control. ABS may also help you prevent your vehicle from jackknifing.

Anti-lock braking systems are only as good as the driver. Learn the correct technique and practise it so that you are ready in an emergency. Read the manual from your vehicle manufacturer to learn how to use your anti-lock braking system properly.

A few tips for emergency stopping with ABS:

- Apply firm, hard continuous pressure to the brake pedal until the vehicle stops.
- Don't pump the brakes. This turns the system on and off.
- Don't be alarmed by brake noise, pedal movement or shudder. This is normal. Keep applying firm pressure.
- Use the vehicle's steering ability to steer around obstacles. Remember that steering and handling characteristics will be affected by the trailer you are towing.

driving tip

Test the four-way flashers before towing a trailer to make sure that activating the truck's flashers will not also activate the trailer's surge brakes.



Some steep hill warning signs show the steepness of the grade. The higher the percentage, the steeper the hill. This hill has an 18 per cent gradient, which is very steep.

Downgrades

There is a practical limit to the amount of heat that brakes can absorb and dissipate. The highest brake temperatures occur on long downgrades. Almost all brake failures and downhill runaway crashes are caused by overdriving the ability of the brakes to deal with heat — in other words, poor speed control.

In many cases, you'll need to descend a hill at a speed below the speed of other traffic to avoid overdriving your brakes. Use your four-way flashers to alert other drivers that you are driving slowly down the hill.

Downshift before you start down any steep hill. This is especially important if you are driving a standard shift vehicle.

If the lower gear doesn't control your speed when going down the hill, apply a steady brake pressure. You must control your speed all the way down every hill so you can respond to any emergency.

You may have to use a runaway lane because of some emergency in the system that will not allow a controlled descent.

Water on roadways

Water entering the brake drums will reduce their braking efficiency. Avoid driving through large amounts of water whenever possible. If you have to drive through water on the roadway, cover the brake pedal with your foot as you approach the water. Place a slight drag (that is, apply a slight constant pressure) on the brakes while you drive through the water. The slight drag placed on the brakes will reduce the amount of water entering the brake drums and shoes. Always reduce your vehicle's speed before driving through large pools of water on the roadway.

During extremely wet conditions, or after driving through water, test your brakes for safe operation. Do this by applying a slight pressure with your foot on the brake pedal. Keep this pressure on for a short distance to dry out the brakes.

Traffic

Don't block traffic. If you're travelling slower than other traffic, such as when going uphill, change lanes or pull over where safe to let other drivers pass. On some highways there are paved areas where you can pull over to let other drivers get past. If a gravel or dirt shoulder looks soft, don't drive on it. The weight of your truck and trailer could cause your wheels to sink into the ground.

definition

Traffic flow refers to the movement of a group of vehicles travelling on one road. The actions of any one vehicle within this group may affect several or all of the other vehicles.

Driving slower than the flow

If you travel more slowly than the traffic flow, you increase your chance of a collision with vehicles travelling behind or beside you. Other drivers will become impatient and follow too closely or try to overtake your vehicle. After passing, they may cut in leaving you with little or no room for a quick stop.

Large vehicles tend to accelerate and travel at speeds that are slower than those used by small vehicles.

You should always use the right lane when you are travelling more slowly than other traffic and are going up or down a hill where a passing lane is provided. In some cases, signs require slower drivers to keep to the right lanes.

Traffic may build behind you when you are driving on a one-lane road and travelling more slowly than other traffic, such as when going up a hill. Allow them to pass as soon as it is safe.

It is a good safety practice to use your four-way flashers when you are driving slowly up or down a hill.

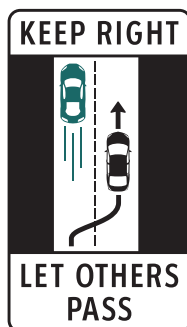

Tailgaters

Tailgaters are easiest to deal with when they are in front of you. It is a good safety practice to allow tailgaters to pass. Watch for these drivers by checking your rear-view mirror frequently.

As a driver of a large vehicle, you must rely on outside mirrors for your rear vision. Tailgaters often sit in the blind spot directly behind large vehicles so you may not be able to see them.

It may not always be possible for you to prevent a rear-end collision caused by these drivers, but if stops are gradual, the impact may be much less.



fast fact

Failure to change lanes and/or slow down when passing a stopped vehicle displaying flashing lights may result in a traffic violation and penalty points.



Traffic-control person ahead.

Stopped vehicles with flashing lights

Drivers must slow down and leave plenty of room when passing stopped vehicles displaying flashing lights to make highways safer for law enforcement, emergency personnel and other roadside workers. This rule applies to all vehicles authorized to display flashing yellow, red, white or blue lights, including those used by fire departments, law enforcement, commercial vehicle inspectors, conservation officers, paramedics, tow truck operators, highway maintenance workers, utility workers, land surveyors, animal control workers and garbage collectors.

When approaching these types of vehicles, you must drive no faster than 70 km/h if the speed limit is 80 km/h or more, and no faster than 40 km/h if the speed limit is less than 80 km/h. (Exception: this rule does not apply if you are on a divided highway and approaching the vehicle with flashing lights from the opposite direction.)

If you are in the lane nearest to the stopped vehicle displaying flashing lights, you must also change lanes to provide safe space margins if it is safe to do so.

Construction zones

Look for construction zones ahead and be prepared to obey traffic-control persons and traffic-control devices within the zone. Remember, road construction doesn't just occur in the daytime.

Just because you don't immediately see traffic-control persons or workers doesn't mean they are not there. Be alert for traffic-control persons, construction workers and equipment. In some construction zones, you may be required to wait for a pilot car to escort you through the work zone. Leave plenty of following distance between your vehicle and the vehicle immediately ahead. Avoid changing lanes in a construction zone. Also leave space between you, the construction crews and their equipment.

Expect delays, and plan for them by leaving early to reach your destination on time. Construction crews aren't there to personally inconvenience you but to improve the roads for everyone. Check radio, television and websites for the latest in traffic reports and updates to find out what is happening on the roads within your area, and along your intended route. Consider taking an alternate route.

Danger zones

The section of road a vehicle must travel through before it can stop is called the vehicle's danger zone. It is physically impossible for you to stop in time to avoid a collision with any object or person that may enter your danger zone.

As your speed increases, the length of your danger zone increases. Less than ideal road conditions, such as rain, snow, ice or gravel, increase the length of your danger zone. Driving your RV at a fast speed in these road conditions increases your danger zone even more.

Reduce your danger zone by slowing down. Remember that it is easier to keep out of trouble than it is to get out of trouble.

You need more room and time to stop if your vehicle is heavy, if your brakes are in less than perfect condition or if the road surface is less than ideal.

Your danger zone is reduced when your vehicle's speed is reduced. You also reduce your danger zone when you cover the brake pedal with your foot any time you see a potential hazard developing (for example, whenever you approach an intersection).

By removing your foot from the accelerator and putting it lightly on the brake pedal when you first see a potential hazard in your danger zone, you reduce the time you need to react. With your foot off the accelerator, your speed is slowing so you have a better chance of stopping before the crosswalk rather than in the intersection.

Prepare yourself when you see a hazard ahead. Take your foot off the accelerator and cover the brake. Your vehicle will slow slightly and you will be able to respond more quickly if you must stop.

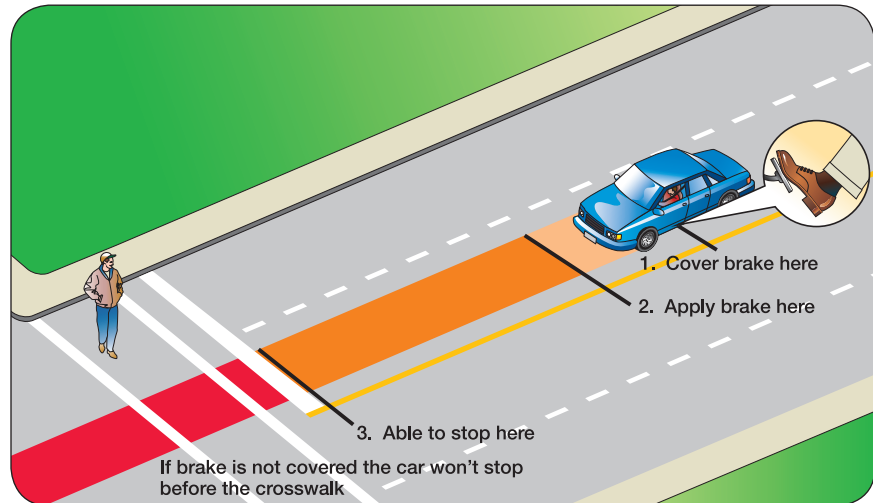

Turns and other manoeuvres

Each truck and RV trailer combination has its own driving characteristics. The extra size, weight and length affect the way these vehicles move, especially around turns and while backing up.

Always remember that you are towing a large RV trailer. You'll need to position your truck carefully to avoid cutting corners or driving over curbs.

Turning radius

How sharply you can turn the front wheels of your vehicle depends on the make and model of the vehicle you are driving. In all cases, the wheel on the inside of the curve (closest to the direction you are turning) will turn more sharply than the wheel on the outside of the turn. The inside wheel will have a shorter turning radius than the outside wheel.

The wheel on the inside of the turn must pivot more sharply to travel on the shorter radius than the wheel on the outside of the turn.

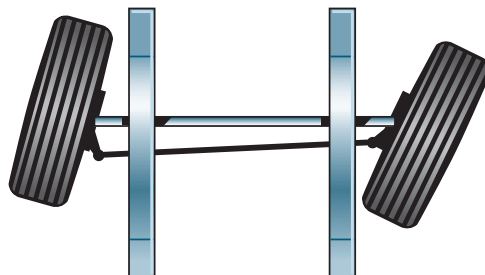

definition

Wheelbase is the distance between the centre of the front wheels and the centre of the rear wheels of a vehicle.

definition

Traction is the friction created between a vehicle's tires and the road.

fast fact

Tires that are in poor condition provide poor traction.

definition

A **full jackknife** occurs when a truck and the trailer form an angle of 90 degrees or less, relative to one another.

Warning: this can happen even at very low speeds. Jackknifing is often caused by poor braking techniques.

The radius is the distance from the centre of a circle to the edge of the circle. When a vehicle turns a corner, it is travelling on a curve. If that vehicle were to continue on the same path, it would eventually drive in a complete circle. The distance from the centre of that imaginary circle to the vehicle's wheel is the turning radius.

A vehicle's rear tires have a different turning radius than its front tires. It is important to know how to judge the turning radius of your front tires to prevent your vehicle's rear tires from cutting the corner.

Off track

When a vehicle moves around a curve, the rear wheels follow a path that is different from the one created by the front wheels. The difference between the path of the front wheels and the path of the rear wheels is called off track. The greater the distance between the front wheels and the rear wheels of a vehicle, or a combination of vehicles, the greater the amount of off track.

Each set of wheels behind the front wheels turn with some off tracking. A truck towing an RV trailer displays several sets of off tracking. The rear wheels of the truck turn somewhat off track from the front wheels, and the wheels of the RV trailer turn with even more off tracking.

The amount of off track is dependent upon a number of factors including the wheel base of the truck, length of the trailer and the location of the pivot point between the truck and trailer (for example, draw bar connection point or location of the fifth wheel). The longer the wheel base, and the longer the draw bar length or the farther back the fifth wheel is mounted, the greater the amount of off track.

Curves and turns

There are several forces that work against you while you move your vehicle around a curve or through a turn. You need to be aware of these and approach each curve at a speed that allows you to safely control your vehicle.

Inertia is the tendency for moving objects — in this case you and your vehicle — to continue to move forward in a straight line. When you brake, inertia tries to keep your vehicle moving. When you go around a curve, inertia tries to keep you going in a straight line.

The faster you are going and the heavier your vehicle, the more inertia will make it difficult for you to move your vehicle off a straight path. This force pushes your vehicle away from the path of the curve. The faster you are travelling, the more difficult it will be to keep your vehicle on the path of the curve.

Traction is the grip your tires have on the road. The amount of traction your tires have with the road's surface determines the amount of control you can maintain over your vehicle. If you enter a curve too quickly and try to slow down by applying your brakes, you may lose traction, causing your vehicle to skid, roll over or jackknife.

Reduce your speed before you enter a curve. Enter each curve at a speed that does not require you to brake and does allow you to apply gradual power while you are in the curve.

Curves

When you curve to the right, take care to keep the front wheels close to the centre line so that your rear wheels do not drop off the pavement or go onto the pavement shoulder.

When you curve to the left, keep the front wheels close to the right edge of the lane to keep your driver's side rear wheels out of the next lane of traffic.



Clearance

Most recreational trailers are tall and wide. You need to know the height and width of your trailer. Pay attention to road signs indicating reduced clearance such as signs for overpasses, tunnels, narrow roads and bridges.

Narrow bridges

Use caution when entering a narrow bridge with a curved approach. You need to be familiar with the amount of off track your vehicle displays and adjust your speed and approach to the curve so that you can enter the bridge safely.

Turning right

When you're operating a vehicle with a lot of off track and you're about to turn right at an intersection, be certain you make your turning arc large enough to give your RV trailer room to follow.

If the turning arc of your front wheels is too small, off tracking may cause the back wheels of your trailer to scrape the curb or even leave the road.

You'll almost certainly crowd anyone, such as a cyclist, who's travelling on your right side. Running your rear wheels over curbs and sidewalks will damage your tires and could seriously injure pedestrians and cyclists. You may hit a power pole, sign post or lamp standard if your vehicle does not have enough room to turn. This type of collision can damage your vehicle, as well as the object it hits.

Check whether smaller vehicles, motorcycles or cyclists are on the right side of your vehicle whenever you make a right turn. The most dangerous point in a turn is when your truck has made the turn but your RV trailer has not. At this point the right rear-view mirror is turned so that it is almost useless.

Make your turns from the proper lanes wherever possible. When it is necessary to move your vehicle outside your lane to negotiate a sharp turn, it's your responsibility to be certain you can move safely without holding up traffic.

Sharp right turns

To make a sharp right turn:

1. Position the vehicle one to two metres from the curb on the approach to the intersection.
2. You will need to drive farther into the intersection before starting to turn than you would if you were not towing a trailer.
3. Enter the turn at a low speed. This will allow you to turn the steering wheel more slowly, which will let you make a smoother turn using less energy.

Turning left

Turning left from a one-way street into a one-way street is similar to making a right turn. In both cases, you must ensure your vehicle's turning arc is large enough to keep the rear wheels of your vehicle from running over or scuffing the curb. In this case, the concern is with the left rear wheels. It's important to check for pedestrians and cyclists before initiating your turn.

These hand positions are recommended for right- and left-hand turns. Always use both hands to steer your vehicle.

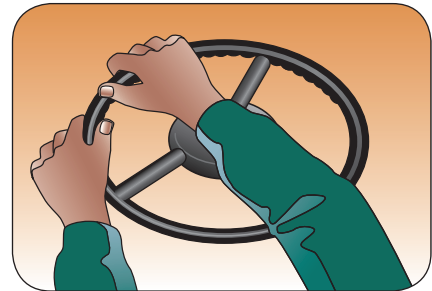
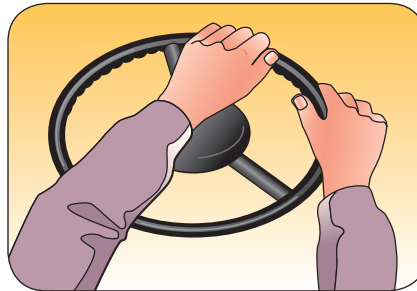

driving tip

By looking ahead, keeping good space margins, and anticipating road hazards, you can avoid sudden stops and changes in speed. These safe driving habits also save fuel.

Seeing and being seen

Large vehicles usually offer a better view of the road ahead and to the sides than passenger cars, but large vehicles also have dangerous blind spots.

Big windshields and a high seat position give you a good view down the road but immediately in front of your vehicle is an area where you cannot see anything. The longer the hood on your vehicle, the longer the blind spot.

Large side mirrors provide a clear view of the road behind you except for the blind spot immediately behind every vehicle.

Check carefully for vehicles and bicycles that may be travelling in your blind spots. Pay particular attention in slow urban areas where cyclists often share the road.

Always stay far enough behind the vehicle you're following to allow you to make your stops in a smooth, gradual way, even if the vehicle ahead makes a panic stop. Giving yourself enough room to make gradual stops will reduce the likelihood of you hitting another vehicle. It will also allow you to give the drivers behind lots of notice that you are reducing your speed. This will reduce your chance of being hit by a tailgater.

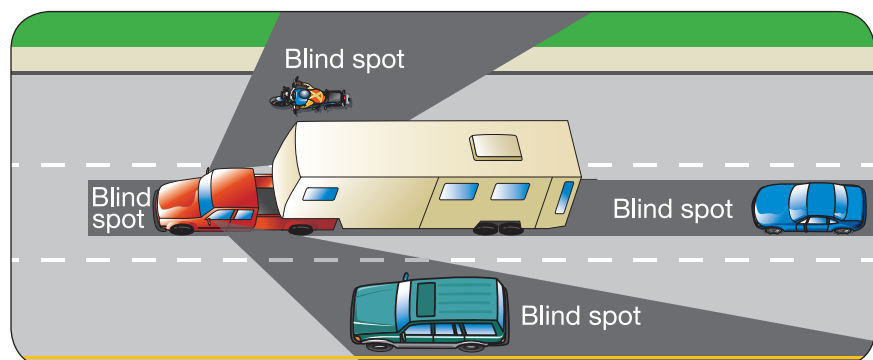

Watch for other drivers who travel in any of your vehicle's blind spots.

Finally, never assume that the other driver has seen you. Many collisions have occurred because drivers did not see something the other driver expected them to see.

fast fact

Convex or spot mirrors may make things look smaller and farther away than they actually are.

Using your mirrors

To drive defensively, it is important to know where your vehicle is in relation to other vehicles on the road. Scan the traffic ahead, behind and to your sides constantly. Look ahead for clues that will tell you whether other vehicles are about to change speed or stop. Frequent checks in your rear- and side-view mirrors will alert you to drivers who are passing or getting ready to pass you. These checks will also help you know whether there are vehicles behind you. Give all drivers plenty of warning whenever you are about to stop, change directions or change lanes.

Looking ahead

You should develop the habit of watching the traffic well ahead of your vehicle. Look for traffic lights, turn signals, pedestrians and vehicles pulling into your lane or making other lane changes. Approach every intersection considering whether the lights are likely to change. When a light has been the same colour for some time it is said to be stale. When you approach a stale green light, expect it to change before you reach the intersection. Be prepared to stop. Traffic lights are synchronized on some streets, so by driving at the posted speed you will make every green light. Adjust your driving speed to take advantage of this.

Lane use

Look ahead for lane-use changes. By watching, you will be prepared if the lane you are travelling in comes to an end or becomes a turning lane.

Be sure that you're in the lane that allows you to go where you want to go.

Passing and being passed

Don't direct other drivers to pass. You may be encouraging them to risk a pass they are not skilled enough to safely complete.

When other drivers indicate they want to overtake your vehicle, help them to pass safely. Reduce your speed and give them room.

Turbulence

Large vehicles travelling at high speeds create varying degrees of air turbulence that can be hazardous to smaller vehicles. Air turbulence is particularly dangerous to cyclists who are much smaller and are likely to be travelling more slowly than large vehicles. Take extra care to be aware of cyclists and give them enough room.

Large trailers can be seriously affected by crosswinds. Be prepared for this. Watch for road signs warning of areas with strong crosswinds, and pay attention to weather reports.

You may also experience turbulence when passing or being passed by large trucks.

If your trailer starts to sway or fishtail, slow down gradually and steer in a straight path if possible. Avoid sudden braking. If your steering is severely affected, pull over and stop.

Choosing your route

Choose your routes carefully. Stay on roads that are suitable for your trailer. Freeways and four-lane highways are best for you.

If possible, avoid towing an RV trailer in city traffic. Towing an RV over high mountain passes puts a lot of strain on the truck.

Always prepare for the possibility of having to turn back. Avoid dead end roads, dirt roads or rocky roads where you may not have enough space to turn around.

Intersections

The area where two or more streets meet is the place where drivers are most likely to be confused. Knowledge of the right-of-way rules (found in **Learn to drive smart**) is essential for all drivers. But don't depend on other drivers to obey these rules.

Reduce your risk of a collision in an intersection by following these common sense practices:

- Don't assume you have the right-of-way, even when your right-of-way is controlled by traffic signs or traffic lights.
- When you're planning to turn, position your vehicle in the proper lane well before the intersection. Signal other drivers well in advance to show them you intend to turn. Reduce your speed gradually before entering the intersection. Turn only when it can be done safely.
- Look left and right before entering any intersection. Look for and expect someone to run the sign or lights.
- Enter a limited-view intersection at a speed that allows you to stop your vehicle safely if you need to.
- Look well ahead for stale green lights. Expect them to change. Decide in advance whether you'll have to stop to avoid running through the light.
- Remember that a combination vehicle is longer and takes longer to clear the intersection than a single unit vehicle.

When the light you are waiting for turns green, check left, right and ahead for any latecomers before you enter the intersection.

- Don't depend on other drivers to signal or make their turns correctly. They may forget to signal; signal and not turn; turn into a wrong lane; or fail to yield.
- Don't change lanes, pass or overtake other vehicles as you are approaching or going through an intersection.

Give full attention to each and every intersection, lane and driveway. Keep your vehicle under full control.

- Don't use your vehicle's size to force other drivers into giving you the right-of-way. Give the right-of-way; don't try to take it. You must move only when you are certain other drivers have given you the right-of-way.



This sign warns of a roundabout ahead.

Traffic circles and roundabouts

These are found in some areas to help ensure safe passage of traffic through an intersection without necessarily stopping the flow of the traffic.

Traffic circles

Traffic circles are mostly found in residential neighbourhoods.

When using a traffic circle:

- Slow down as you approach the circle.
- Obey any posted traffic control signs, such as “Yield” or “Stop” signs. If there are no traffic control signs, treat the intersection as an uncontrolled intersection.
- Yield to any traffic in the traffic circle. If another vehicle arrives at the traffic circle at the same time as you do, yield to the vehicle on your right.
- Go around the traffic circle to the right (that is, in a counter-clockwise direction).

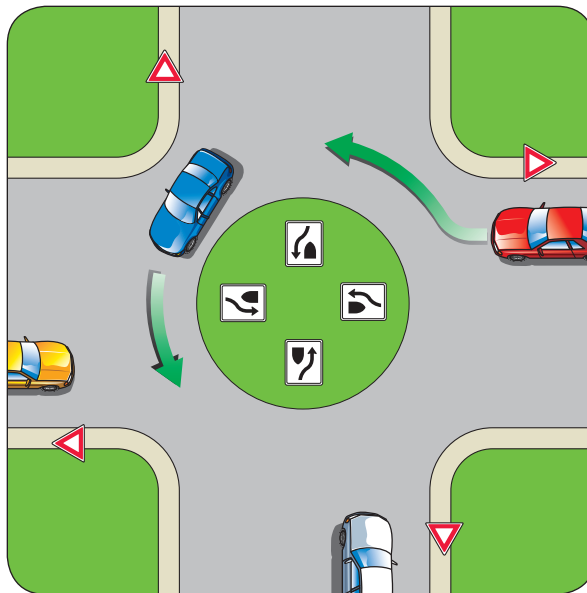

You must turn right to enter a traffic circle and right again to leave it. Yield to vehicles that are already in the traffic circle. If another vehicle arrives at the traffic circle at the same time as you do, yield to the vehicle on your right.

driving tip

Emergency vehicles displaying flashing lights and sirens always have the right-of-way. If an emergency vehicle is approaching, avoid blocking a traffic circle or roundabout. Stop for the emergency vehicle before entering, or exit the traffic circle or roundabout and then stop to allow the emergency vehicle to pass.

Roundabouts

Roundabouts are generally larger than traffic circles.

Some roundabouts have more than one lane. Lane use signs and markings may be displayed at the approaches to indicate where you can go in each lane when you are in the roundabout. Make sure you know where you want to go — and are in the proper lane to get there — before you enter a roundabout. Do not change lanes in a roundabout.

Roundabouts often have a truck apron around the central island which large vehicles may use to help them to get through the roundabout.

When you use a roundabout:

- Know where you want to go before you enter a roundabout, and enter the correct lane. Lane use signs or road markings will show you which lane you need to use.

If you want to turn left, make sure you are in the left lane. If you want to turn right, use the right lane. If you want to go straight, you may use either the left or right lane.

- Slow down as you approach the roundabout.
- Yield to pedestrians that may be crossing or about to cross in the crosswalk located in advance of the roundabout.
- Yield to any traffic already in the roundabout.
- Go around the roundabout in a counterclockwise direction. Don't change lanes in a roundabout.
- Don't ride alongside large vehicles such as trucks and buses in roundabouts. They may need more than their lane to go through the roundabout.
- If you entered the roundabout in the left lane, stay in that lane. You may either go straight or turn left from that lane.
- Signal "right" before you exit.

When you leave the roundabout, be prepared to yield to pedestrians who may be in the crosswalk where you are exiting.

Slow down when approaching a roundabout and yield to traffic already in it. Stay in the same lane that you approached the roundabout from. Don't drive alongside large vehicles such as trucks and buses in roundabouts.



This sign warns to keep away from large vehicles such as trucks and buses in a roundabout.

Take care when driving through a roundabout when towing an RV trailer. Due to your vehicle's off track, you may need to take up more than one lane. Make sure there are no vehicles in the lane beside you in the roundabout.

In the example above, the red car has entered the roundabout from the south in the right lane after first yielding to vehicles in the roundabout. The driver may either turn right at the east exit or continue straight and take the north exit.

The blue car entered from the south in the left lane, and has merged into the left lane in the roundabout. Because the blue car entered from the left lane, the driver cannot immediately turn right at the first exit (east), but can take either the north or west exit.

The truck towing an RV trailer entered the roundabout from the east in the left lane and the driver is going to take the south exit. Note that due to the length of the combination, the RV trailer is partially in the right lane.

The driver of the green car must yield to the truck and RV trailer already in the roundabout.

fast fact

The maximum speed in a lane or alley is 20 km/h unless otherwise posted.

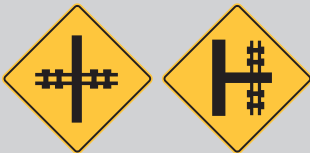

Two road signs that alert you to a railway crossing ahead.

Alleys, lanes and side roads

If you drive from an alley, lane or side road onto a highway, you must:

- Stop your vehicle immediately before you drive across the sidewalk or sidewalk area.
- Yield the right-of-way to pedestrians in the sidewalk area and to motor vehicles on the highway.

Railway crossings

Railway crossings require extra caution. Large vehicles need more space and more time to respond to conditions, so you need to be particularly careful to check whether a train is in the area. You also need to note the condition of the track and whether your vehicle will have any difficulty making a crossing.

Controlled and uncontrolled crossings

All vehicles must stop at all controlled railway crossings if signalled to do so. A controlled crossing is one that has a flagperson, stop sign, crossing gate or an electric or mechanical signaling device.

Where you must stop for a railway crossing:

1. Stop five to 15 metres away from the railway crossing.
2. Look both ways and listen for any approaching trains.
3. Move forward when safe. Don't shift gears while crossing.

Don't park any vehicle within 15 metres of the nearest rail of a railway crossing.

Don't cross a railway track under any circumstances if a railway crossing gate is in the down position.

Minimize your crossing time — Before you cross a railway line, check that the track is clear far enough to give you at least 10 seconds to cross — more if your vehicle requires it or if you are crossing more than one track at a time.

Watch for humpback crossings — Over time, humps often form at railway crossings. They present a danger to many low-clearance vehicles.

Acts of nature

No matter how well you prepare yourself and your vehicle, there will always be conditions beyond your control that you'll have to respond to when driving. These include a wide variety of weather conditions and the hazards brought on by darkness.

Night Driving

You cannot see as far in the dark. You need to travel at a speed that allows you to stop within the distance you can see. When light levels are low, you may need to drive below the posted speed limit.

Most headlights illuminate the highway for only 100 metres on high beam and even less on low beam. Poor weather, glare and fatigue will reduce how far you can see. Adjust your speed for the conditions.

Even when you travel at the legal speed you can overrun your lights. The distance you need to stop at high speeds can exceed the distance that your high beams will allow you to see under good conditions. Slow down to ensure you can see problems developing in time to stop for them.

Some tips for driving at night:

- Reduce your speed after sunset. Remember that your vision isn't as efficient as it is in daylight.
- Ensure your lights are clean and working — see and be seen.
- Use parking lights only for parking. It is illegal to drive at night using only parking lights.
- Switch your lights from high beam to low beam at least 150 metres away from any vehicle you are approaching or following. This will reduce the glare from your headlights on the eyes of other drivers.
- Don't flash your lights at drivers who forget to switch their lights from high beam to low beam. Instead, slow down and focus your eyes on the right edge of the road to watch for pedestrians and obstacles.

fast fact

On average, 9,900 crashes per year in B.C. involve animals.

ICBC reported five year average from 2009 to 2013

On average, 450 people are injured and four people are killed in crashes involving animals each year in B.C.

Injury data: ICBC reported five year average from 2009 to 2013

Fatals data: Police data five year average from 2010 to 2014

Animals on the road

In B.C., animals on the road are a major hazard. Crashing into a large animal can cause damage and injury, not just to the animal, but to you and your passengers.

To help prevent a collision with an animal:

- Watch for animal crossing signs and slow down in these areas.
- Slow down and use caution when you see wildlife on or near a highway, so you can react in case it crosses your path.
- Be alert, especially at dusk or dawn.
- Look for sudden, unusual spots of light on the roadway at night. This may be the reflection of your headlights off an animal's eyes.

- Take extra caution in spring and fall — vegetation in the ditches along the side of the road in spring is an attractive source of forage for many wildlife species, and in fall, many animal species are on the move during the mating season.
- Remember that wild animals often move in herds. If you see one animal, there are likely more.

If an animal is directly in front of you:

- Check your rear-view mirror to see if there is a vehicle behind you.
- Assess the risks and decide on an action. Can you stop safely? Would vehicles behind you be able to stop safely? Can you steer around the animal? Would it be better to hit the animal and risk a crash?
- Slow down but resist the urge to slam on your brakes when you see an animal. This could send your vehicle out of control.
- Leave a wide margin when you drive around an animal. A frightened animal may run in any direction.
- If the animal is large and you can't stop in time, brake firmly and steer to strike the animal at an angle. Let up on the brake pedal just before hitting the animal. This will cause the front of your vehicle to rise and reduce the chance that the animal will come through the windshield.

Coupling

Always take care when coupling your truck to a recreational trailer.

1. Block the trailer wheels.
2. Ensure that the area is clear and that your trailer is ready to be coupled to your truck. It's helpful to have another person act as a guide.
3. Inspect the coupling device on the truck. In the case of a fifth wheel, make sure the coupler jaws are open.
4. Check the trailer hitch or kingpin and pin box. Ensure they are in good condition.
5. Enter the truck and start the engine. Release the parking brake and sound the horn. Back the truck slowly to the front of the trailer. Ensure the truck is in direct line with the trailer and that the fifth wheel opening or ball is in line with the trailer kingpin or hitch.
6. Stop the truck just before the coupler makes contact with the trailer. Place the truck in Park (or low gear if manual transmission), and set the parking brake.
7. Exit the truck and check that:
 - the fifth wheel or ball hitch is securely attached to the truck (if fifth wheel, make sure it is tilted down and is locked in place on the truck bed).
 - the trailer is slightly higher than the middle of the fifth wheel or ball and placed so that it lines up with the middle of the coupling device. If necessary, adjust the height of the trailer by cranking the stabilizers up or down.

driving tip

If the truck and trailer are lined up, you should be able to see an equal portion of each side of the trailer in each mirror.

driving tip

Check that all the trailer lights work after they are connected to the truck, including clearance lights, tail lights, brake lights and licence plate light.

driving tip

Always block the trailer wheels. The blocks are the only way to hold the trailer in position once you have disconnected it from the truck.

8. Re-enter the truck. Release the parking brake and sound the horn. Back slowly under the trailer. Stop when you feel or hear the kingpin lock into the fifth wheel (with a ball and hitch, stop when the ball is centred under the hitch). Set the parking brake and put the truck in Park (or low gear if manual transmission).
9. Exit the truck and inspect the coupling:
 - **Fifth wheel connection:** the fifth wheel jaws have engaged the kingpin and are closed and locked (the safety latch is over the locking lever).
 - **Ball and hitch:** lower the trailer hitch over the ball, then lock the hitch.
10. Connect the electrical cable for the trailer brakes and lights. Secure the breakaway switch cable to the tow vehicle.
11. Raise the trailer stabilizers slightly and remove the trailer wheel blocks.
12. Re-enter the truck and release the parking brake.
13. Move the vehicle ahead slowly and apply the trailer brakes to check that they work and that the hitch connection is secure.
14. Set the parking brake and place the truck in low gear (or Park if automatic transmission).
15. Exit the truck. Raise the stabilizers completely. Before getting back into the truck and driving away, walk all around the trailer to ensure it is clear.

Uncoupling

Always take care when uncoupling your truck from an RV trailer. Follow these steps:

1. Place the trailer where you want to leave it. Ensure the surface is level and will support the trailer. Also make sure the truck and trailer are in a direct line.
2. Set the parking brake and place the truck in Park (or low gear if manual transmission).
3. Exit the truck. Block the trailer wheels.
4. Lower the stabilizers until they touch the ground and pressure is released off the hitch. Check the trailer stabilizers or pads to ensure the surface is firm enough to support the trailer. You may want to place blocks of wood beneath the stabilizers if you are parking on hot asphalt or some other soft surface.
5. Disconnect the electrical cable for the trailer brakes and lights. Also disconnect the breakaway switch cable from the tow vehicle.
6. Pull the fifth wheel or trailer hitch handle lock pin to release the coupler/jaws. With a ball and hitch connection, raise the stabilizers so that the ball will clear the hitch.
7. Re-enter the truck. Release the parking brake and slowly drive the truck forward until the truck begins to clear the trailer. Set the parking brake, place the truck in Park (or low gear if manual transmission), and exit the truck.
8. Re-check the trailer stabilizers or pads to ensure the trailer is level and the surface supports the trailer.
9. Re-enter the truck. When safe, slowly drive the truck forward away from the trailer.

Parking

It is important to ensure your vehicle stays in place when parked. Use the following precautions to prevent a runaway vehicle:

- Set the parking brake in the truck.
- Place the transmission in the lowest forward or reverse gear or park.
- Stop the engine. Lock the ignition and remove the ignition key.
- If you are parking on an upgrade, always turn the wheels towards the centre of the road.
- If you are parking any vehicle on a downgrade, always turn the wheels towards the edge of the roadway.
- You should block the wheels of any large vehicle parked on even a slight grade.

driving tip

A simple method of backing up your trailer is to position your hands at the five o'clock and seven o'clock positions on the steering wheel.

Then, using both mirrors, turn the steering wheel in the direction you want to go. For example, if you want your trailer to go left, move your hands to the left. This will actually turn your steering wheel to the right.

Backing up

Backing up with a trailer is different than backing up a single vehicle. It must always be done with extreme caution. With few exceptions, you will be responsible for any crash that happens when you are backing up. This manoeuvre becomes dangerous any time you don't make certain the way is clear.

Investigations of crashes that involved a vehicle backing-up show that these crashes are usually caused by drivers who did not see something they should have seen. Follow these tips:

- Check the rear by walking behind the trailer to make sure the way is clear.
- Check for objects near your intended path such as electrical and water hookups, and overhead objects such as tree branches.
- Have someone help you by acting as your guide. Choose a reliable guide and make sure you agree on communication signals. Remember, you are still responsible. Position your guide where there is a clear, continuous view of the backing path your vehicle will follow. You must be able to see the guide throughout the manoeuvre.
- Back up slowly, at walking speed. Sound the horn before backing up and at least once every vehicle length to warn other road users.
- If possible, back toward the left side of your truck where you can see the trailer over your left shoulder. This is easier than backing toward the right side — called the blind side — of your truck.

Avoid turning the steering wheel too much and don't hold it in the turned position too long. This could result in jackknifing the trailer. If this happens, you will have to pull forward before you will be able to try backing up again.

Disabled vehicles

Any vehicle presents a hazard when it is parked on the side of a road. Large vehicles present more significant hazards. You should put out warning devices if you park your RV at the side of the road in an area not designated for parking, such as:

- two red flags that measure at least 30 cm by 30 cm, or two warning devices that have been approved for daylight use — these may include flares, fuses and reflectors
- flares, fuses, reflectors and red lanterns approved for night use.

If your vehicle becomes disabled:

- move it as far off the travelled portion of the highway as possible
- place warning devices approximately 30 m ahead and 30 m behind the disabled vehicle.

Note: It is a good safety practice to place additional warning devices further than 30 m from your vehicle.

Personal safety

Carbon monoxide poisoning

Carbon monoxide poisoning is an ever-present danger when you operate a motor vehicle. Carbon monoxide is a gas that can seep into a driving compartment and make you dizzy or drowsy. Too much of it will make you pass out, which will almost inevitably result in a crash if you are driving. Carbon monoxide can kill you if you continue to breathe it in after you pass out.

Carbon monoxide is especially dangerous because it is odourless, colourless, tasteless and difficult to detect. It's in the exhaust of every motor vehicle. Because it is so difficult to tell when carbon monoxide is present, it's essential that you check your exhaust system for leaks frequently to ensure that no exhaust fumes are entering the driver's compartment.

Never run your engine in a closed garage. Don't follow any vehicle too closely, and maintain a safe distance between your vehicle and the one in front of you when you're stopped at traffic lights or stop signs.

If you feel dizzy or drowsy while driving, pull over to the side of the road. Get out and get plenty of fresh air.

fast fact

It's estimated that the correct use of a lap and shoulder belt system reduces the likelihood of death in a motor vehicle crash by 50 per cent.

Seatbelts

There's no question — seatbelts do save lives. Transport Canada estimates that wearing seatbelts has saved an estimated 2,400 lives and prevented 55,000 injuries in the past 10 years.

During a crash, seatbelt systems reduce the risk of occupants striking the interior of the vehicle, colliding with other passengers or being ejected. If you are belted in, you are much less likely to become injured or knocked out in a collision. Staying conscious gives you a better chance of getting out of your vehicle quickly if it catches fire or lands in water. Even during normal driving

conditions, a seatbelt can prevent you from bouncing around the interior of your vehicle, which will help you maintain better control on rough roads or during collision-avoidance manoeuvres.

Many people think they can protect themselves in a collision. You can't hold yourself back during a collision, no matter how strong you are.

Thousands of kilograms of force work against unbelted persons during the rapid deceleration that takes place during a crash.

Use the following rules to ensure your seatbelt fits correctly:

- place the lap belt low over the pelvis, not over the soft stomach area — make certain it is snug
- ensure the shoulder strap is snug across the chest
- never place the shoulder strap under the arm or behind the back
- remove all slack.

Airbags and head restraints

Even if your vehicle is equipped with airbags, you must wear your seatbelt. Airbags can seriously injure unbelted occupants. You must allow at least 25 cm (10 in) between your breastbone and the airbag unit in the steering wheel. This distance will minimize the risk of injury if the bag deploys.

Head restraints can help prevent soft tissue injuries such as whiplash. Whiplash is an injury to the neck, head and or shoulders after being subjected to a snapping motion. Adjust your head restraint so the top is at least level with the top of your head. Position your head restraint as close to the back of your head as possible. It may be necessary to adjust your seat back position to do this. Closer head restraints can be twice as effective in preventing injuries than if they're set too far back.



Make sure your head restraint is adjusted to the height that's right for you.



If you are in a crash and your head restraint is not properly adjusted, this can be the result.

crash fact

Studies show that drivers who are talking on a cell phone lose about 50 per cent of what is going on around them visually. When you are stopped at an intersection or slowed in traffic, you are still driving and could be subject to a fine, penalty points and the driver risk premium.

Source: IIHA (Insurance Institute of Highway Safety).

Cellphones and other devices

Research shows that using a cellphone or other electronic communication device while driving significantly increases the risk of crashing. All B.C. drivers are prohibited from using hand-held electronic devices while driving. Drivers are prohibited from operating or holding hand-held cellphones or other electronic devices, sending or reading emails and/or text, operating

or holding hand-held music or portable gaming devices, and manually programming or adjusting GPS systems while driving. These restrictions do not apply for calling 9-1-1 to report an emergency.

Experienced drivers (not in GLP) continue to be permitted to use hands-free cellphones and devices that only require touching a single button to activate or de-activate, and where that single button is located in a fixed and secure location. This includes pre-programmed or voice-activated GPS devices. Two-way radios used by industry (for example, trucking, logging, oil and gas) are also permitted.

Even if you do need to make or receive a hands-free call, it is safer to pull over to the side of the road as soon as it is safe to do so.

fast fact

If you're convicted of impaired driving and you caused a crash, the cost of your vehicle insurance will increase. In addition, ICBC will not pay to repair or replace the vehicle. ICBC can also recover from you all costs associated with the crash, including any victim's claim.

fast fact

B.C. now has tougher drinking and driving laws. You can count on penalties adding up to \$600 to over \$4,000 — even if it's the first time you're caught — and more time off the road.

For more information on B.C.'s impaired driving laws, go to icbc.com, the RoadSafetyBC website and the Justice Laws Website.

Impairment

Your life and the lives of others depend on your ability to remain alert and fully functioning when you are behind the wheel. Alcohol, illicit drugs (for example, marijuana and cocaine), and even some prescribed drugs or over-the-counter medicines can reduce (impair) your ability to function safely.

If you are convicted of driving while impaired, the Superintendent of Motor Vehicles will review your driving record and may increase any length of time the courts have prohibited you from driving.

If you drive while prohibited and are stopped by the police, the vehicle you are driving may be impounded for a minimum of 60 days. On a second offence the vehicle may be impounded for a minimum of 90 days.



Prescribed and over-the-counter drugs

Using medication when you drive can be risky. Antihistamines, sedatives, tranquilizers and even some cold remedies can cause drowsiness and decreased alertness. Read the warning on the label for any side effects that may impair your ability to drive safely. If in doubt, check with your pharmacist or physician. Certain combinations of seemingly harmless medications can markedly decrease your ability to function safely.

Penalties for impaired driving

Immediate and severe penalties apply if:

- you drive with a certain amount of alcohol or drugs in your system, or
- you refuse to provide a breath sample.

As well, the penalties become more severe for repeat offences.

Note: You may be prohibited if a police officer considers your ability to drive to be affected by alcohol or drugs. You do not have to have a BAC level of over .08 or a BDC of 2 nanograms or more THC.

Criminal Code penalties

If you're convicted of a *Criminal Code* driving offence for impaired driving due to alcohol or drugs, you're looking at some very serious penalties which could include lifetime driving prohibitions and time in jail.

	Driving while impaired or Blood Alcohol Content (BAC) over .08 or refusal to provide sample			Impaired driving causing bodily harm	Impaired driving causing death
	1 st Offence	2 nd Offence	3 rd Offence		
Prohibition from driving	1–3 years	2–5 years	3 years – lifetime	Up to 10 years	Up to lifetime
Fine	\$1,000 and up	No maximum	No maximum	No maximum	No maximum
Jail	0–5 years	30 days – 5 years	4 months – 5 years	Up to 10 years	Up to life imprisonment

fast fact

If you are prohibited from driving during your novice stage, you'll lose any time you have accumulated toward graduating out of the Graduated Licensing Program. In other words, the "clock is reset to zero."

Graduated Licensing Program

Penalties are strict when you are in GLP. If you violate the zero blood alcohol content restriction, or operate a vehicle while under the influence of drugs, you may be subject to various penalties, including an immediate roadside suspension or prohibition, a fine, driver penalty points and/or having your vehicle impounded.

The suspension or prohibition and the penalty points will be recorded on your driving record and may lead to a much longer driving prohibition. More violations could lead to an even longer prohibition period.

If you are prohibited from driving during the novice stage, you will lose any time you have accumulated toward graduating out of GLP. This means that once your licence is reinstated after a prohibition, you start at the beginning of the novice stage again, and you will need to be prohibition-free for 24 consecutive months before you're eligible to take the road test to exit GLP.

fast fact

If you drive while prohibited, you may face significant penalties including a stiff fine and jail.

Other costs of impaired driving

Besides the penalties listed above, there are other costs involved if you are caught driving while impaired:

Money — if you are convicted of impaired driving and you cause a crash, your insurance claim may be denied, including claims for damage that you might cause to your vehicle, or to other people or property. You could be responsible for paying these costs. As well, your insurance rates will increase and you will receive a driver penalty bill.

Job — an impaired driving conviction can prevent you from holding certain jobs.

Travel — an impaired driving conviction could create problems for you when travelling to certain countries, including the U.S. and Mexico.

Vehicle impoundment

In addition to impounding vehicles operated by impaired drivers, police can also impound the vehicle you are driving if you are caught committing any of the following offences:

- driving while unlicensed
- driving while suspended or prohibited
- excessive speeding (40 km/h or more over the posted limit)
- street racing or stunt driving
- riding (or allowing a passenger to ride) while improperly seated.

Police can immediately impound the vehicle for seven days, which could escalate to 30 or 60 days for repeat offenders. The owner is then required to pay the vehicle towing and storage fees to get their vehicle back.

It's important for vehicle owners to understand that they are responsible for making sure that only licensed drivers use their vehicles. For example, if an employer allows a prohibited or unlicensed driver use of a company vehicle, the vehicle could be impounded.

Fatigue

Long road trips and driving day after day can easily make you fatigued and affect your ability to make good decisions.

There is no safe substitute for proper rest or sleep. Check yourself frequently to see whether the effects of fatigue are starting to show when you are driving for long periods. If you are relying on stimulants such as coffee to help you stay awake or if you are having trouble sleeping, you are likely suffering from fatigue. Pull over in a safe location and get some sleep.

Emotions

Your emotions can also impair your ability to drive safely. Emotional disturbances can distract drivers and prevent them from focusing on the task of driving.

Safe driving demands your full attention at all times. You'll be exposed to drivers of all kinds — from the most skilled to those who surprise other drivers with unexpected manoeuvres.

Your safety depends on your ability to give your complete and constant attention to your driving while you are behind the wheel. There is no room for road rage or any other distracting emotion.

Passengers

Never drive with people inside your trailer. It is illegal and unsafe. All occupants must be in the truck.

Loading your trailer

The way you distribute items carried in your RV will affect the handling of your truck and trailer. Improper loading can cause the trailer to sway, resulting in loss of steering control or the trailer flipping over while turning. Try to distribute weight as evenly as possible between the left and right sides, and along the length of the trailer. Also keep weight near the bottom of the trailer; store heavy items near the floor rather than near the ceiling. Make sure everything is secure and braced to prevent movement. Cupboards should be locked so that their contents don't spill. Remember also that you need more weight toward the front of the trailer than toward the rear. You want to have 15 to 25 per cent of the trailer weight on the fifth wheel or hitch connection (pin weight or hitch weight).

driving tip

Make sure propane is shut off before you refuel your truck.

Propane leaks are dangerous, as propane vapour can explode.

Propane

Many trailers have a propane stove, refrigerator, hot water tank and heater. RVs with propane appliances should be equipped with propane detectors, which will sound an alarm if there is a propane leak. If you suspect a leak, go outside immediately, turn off the propane at the tank, open all the windows and door, and get an expert to fix it. Always turn off all propane appliances including pilot lights before towing an RV.

Safety equipment

Always carry safety equipment that you could use or might need in emergencies, such as flags or flares, a first aid kit and fire extinguishers. You may need to carry a hydraulic jack in case you need to change a tire on your trailer.

fast fact

Diesel fuel is toxic and should never be touched with your hands or cleaned up with a cloth.

Fire

Preventing fires in and around a vehicle is easier and cheaper than fighting a vehicle fire.

- Never start a vehicle with a fuel leak. Repair the leak and use an appropriate absorbing material to soak up the spilled fuel. Dispose of your cleaning material in an appropriate container.
- Shut off engines when refueling vehicles.
- Don't smoke in garages or near fueling areas.

It's always a good idea to keep a fire extinguisher in your vehicle.

Firefighting

Fighting a fire requires quick thinking, fast action and some understanding of firefighting. Learn whether there are fire hazards associated with your vehicle.

- Don't risk your own life. Fuel fires can spread quickly or explode.
- Tell the first spectator to call the fire department. Warn others if there is any danger of an explosion of gasoline or flammable goods, or of exposure to toxic substances. Tell them to keep back a safe distance.
- Assess the situation and decide whether it is safe to take any further action.
- If possible, disconnect the truck from the trailer and separate the units to a safe distance apart. Do this only if you are certain it can be done without putting yourself in danger.
- Fight fires with the wind at your back whenever possible. This reduces the chances of you being asphyxiated.
- If the fire is in your electrical system, disconnect the battery cables. When a vehicle is in a crash, shutting off switches and disconnecting battery cables can prevent fires that may be caused by leaking fuel.
- If a fire starts under the hood, direct the extinguisher from underneath the vehicle or through the radiator. Do not open the hood to fight the fire.
- Use your extinguisher to put out the flames, but try to keep some extinguishing fuel in reserve to fight possible flare-ups.
- Do not use water on gasoline or oil fires. Water will spread these fires. Use an appropriately rated extinguisher, sand or dirt to smother them.

Fire extinguishers

There are two main categories of fire extinguishers: multi-purpose dry chemical extinguishers and carbon dioxide (CO₂) extinguishers. The multi-purpose dry chemical extinguishers are easier and safer to use, while the CO₂ extinguishers are more effective.

Multi-purpose dry chemical extinguishers are available in two classes. A cylinder marked BC can be used to put out grease, oil, gasoline and electrical fires. A cylinder marked ABC will also put out Class A fires such as paper, cloth, etc.

CO₂ extinguishers are extremely effective but should never be used in an enclosed space. There is a risk that you could smother yourself if you use these in too confined a space. There's also a risk that you could blister your skin.

Before leaving a campground

- Close the valves for the sewer and gray water and unhook the septic system.
- Unhook the water hose and make sure that you have only enough water with you to get to your next stop. (Extra water means extra weight.)
- If your RV has slide-outs or awnings, make sure they are retracted and fastened.
- Unhook the power line.
- Make sure that roof vents are closed and TV antennas and satellite dishes are retracted.
- Check around inside to make sure that all items are properly stored and there is nothing loose on a counter or table.
- Make sure that the fridge is locked.
- Turn off all pilot lights and all propane tanks.
- Put up the steps.
- Make sure that trailer jacks and supports are raised and secured.
- Move the picnic table if it's in your way.
- Check around the campsite to make sure that nothing has been left behind.
- Make sure you have all your maps and know which way to go.
- Conduct a pre-trip inspection as described in chapter 3 of this guide.
- Check fuel gauge or electricity. Make sure you've got enough fuel.

driving tip

It's a good idea to take the fifth wheel trailer out for a short drive every month to prevent damage to the tires from sitting in one position for too long.

Storing your recreational trailer

When you're not using your RV:

- Empty all water and holding tanks. Remove the drain plug from the hot water tank and rinse out the tank. Pump RV antifreeze through the system until all water is removed from the water lines.
- Turn off the propane cylinders and cover the regulator.
- Remove all perishable food from cabinets, and leave cabinet doors slightly open to allow air circulation.
- Turn off the refrigerator, remove all food, and leave the fridge door open.
- Clean the interior of the trailer and close the blinds.
- If possible, leave a window or roof vent slightly open for air circulation.
- If storing your RV for long periods of time or in damp conditions, place moisture removers inside the trailer.
- Remove batteries and store in a dry place. Batteries should be charged every two to three months; check with your RV dealer.
- Cover the tires if they will be exposed to the sun or damp ground.
- Place the trailer on jack stands or blocks to prevent damage to the tires and wheel bearings.
- Check your stored trailer every month or so to ensure that there are no leaks or damage. Also check for animals that may have gained entry.

driving tip

Frequently check the wiring connection for corrosion. This connection is often the reason why trailer lights don't work.

Maintaining your RV trailer combination

Towing an RV trailer causes extra wear and tear on the tow vehicle, and results in more frequent maintenance, including:

- engine and transmission oil changes and filters
- lubrication of steering and suspension components
- cooling system maintenance
- brakes on both the truck and trailer
- tires and wheel bearings on both the truck and trailer.

Remember to check the following frequently:

- Fifth wheel or other type of trailer connection — make sure it is securely attached and all bolts are tight.
- Wiring — make sure that the wiring connection to the trailer is clean and shielded from moisture, and that electrical connectors are not corroded.
- Lights — check that all lights are working on both the truck and trailer.
- Batteries — keep batteries fully charged. If you have electric brakes on the trailer, make sure the battery for the emergency trailer breakaway system is kept charged. If it runs down, it could affect the operation of the emergency breakaway switch.

This chapter is a handy reference section that gives examples of the most common signs, signals and road markings that keep traffic organized and flowing smoothly.

- Signs
 - regulatory signs
 - school, playground and crosswalk signs
 - lane use signs
 - turn control signs
 - parking signs
 - reserved lane signs
 - warning signs
 - object markers
 - construction signs
 - information and destination signs
 - railway signs
- Signals
 - lane control signals
 - traffic lights
- Road markings
 - yellow lines
 - white lines
 - reserved lane markings
 - other markings

Signs

There are three ways to read signs: by their shape, colour and the messages printed on them. Understanding these three ways of classifying signs will help you figure out the meaning of signs that are new to you.



Stop



Yield the right-of-way

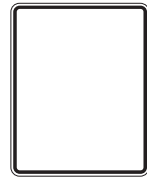

Shows driving regulations

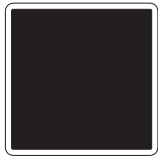

Explains lane use

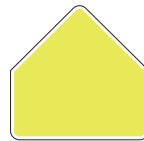

School zone signs are fluorescent yellow-green

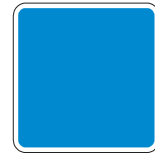

Tells about motorist services



Shows a permitted action



Shows an action that is not permitted



Warns of hazards ahead



Warns of construction zones



Railway crossing



Shows distance and direction

Regulatory signs

These signs tell you about driving laws and regulations. It is an offence under the B.C. *Motor Vehicle Act* to disregard them. Drivers who do not follow the instructions on these signs may receive penalties.



Stop completely — continue only when safe



Give the right-of-way to other vehicles and crossing pedestrians



The maximum legal speed when the road is bare and dry and visibility is good



Indicates a lower speed limit ahead



Do not enter



Do not go this way — usually mounted on exit ramps



One way — gives direction of traffic on cross street



Winter tires or chains must be used when sign is displayed



Stay off this road during major disasters — road may be used only by emergency vehicles



Move into right lane if driving slower than regular traffic



Keep right unless passing



Passing lane ahead



Do not pass

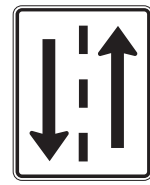

Two-way traffic — keep right unless passing



Keep right of the divider



No stopping between here and the next no-stopping sign



No stopping during posted times between here and the next sign



No bicycle riding beyond this point



No right turn on red light



Slow vehicles to use pullouts for the next stated distance



Slow vehicle pullout stated meters ahead



Slow vehicle pullout



Slow traffic delaying 5 vehicles must use pullout



Slow traffic delaying vehicles use pullouts

School, playground and crosswalk signs

These signs tell you the rules to follow in areas where you need to be extra cautious.



Pedestrian activated crosswalk — prepare to stop if the light is flashing



Pedestrian crosswalk — yield to people crossing



School crosswalk — yield to pedestrians — if there is a crossing guard, follow directions



School zone — reduce speed when children are present



Playground nearby — be prepared to slow down



Playground zone — 30 km/h limit is in effect every day from dawn to dusk



School zone — 50 km/h limit is in effect from 8 a.m. to 5 p.m. on school days when children are on the roadway or shoulder



School zone — if the tab underneath only indicates the speed limit, that limit is in effect from 8 a.m. to 5 p.m. on school days



School zone — the tab underneath indicates the speed limit and the hours that it is in effect (in this case, the 30 km/h limit is in effect from 8 a.m. to 5 p.m. on school days)

Lane use signs

Signs showing which lanes may be used to turn or go straight are mounted above the lane or at the side of the lane before the intersection. If you are in a designated lane, you must follow the direction indicated by the arrows. You may not move into or out of a designated lane while you are in an intersection.



Turn left only



Continue straight only



Go through or turn left



Go through or turn right



Vehicles from both directions must turn left, no through traffic allowed



Vehicles in both these lanes must turn left

Turn control signs

Turn control signs are mounted directly above the intersection. You must follow the direction of the arrow.



Left turn only



Go straight only
— no turns



Turn right or left
only



No right turns during
posted times

Parking signs

Parking signs let you know where and when you are allowed to park. You may receive fines or your vehicle may be towed (or both) if you park illegally.



Time-limited parking
during posted times



Do not park
here



Parking is not
allowed during
posted times



Parking only for vehicles
displaying the disabled
parking sign and carrying
a person with disabilities

Reserved lane signs

A white diamond painted on the road surface marks reserved lanes. Reserved lane signs are also placed over or beside lanes that are reserved for certain vehicles such as buses or high occupancy vehicles (HOVs). Other HOV signs may give additional information on who may use the HOV lane.



Only buses in this lane



Only buses and HOVs
in this lane — may show
how many people must
be in the HOV



Curb lane of cross street
ahead is a reserved lane

Warning signs

Most warning signs are yellow and diamond-shaped. They warn of possible hazards ahead.



Winding road ahead



Hidden side road ahead



Sharp curve ahead — slow to suggested speed



Curve ahead — slow down



Merging traffic ahead



Road merges with another road — added lane to the right ahead



Right lane ends ahead



Divided highway ends ahead — keep right



Two-way traffic ahead



Road narrows ahead



Narrow structure ahead — often a bridge



Bump or rough road ahead



Road may be slippery ahead



Steep hill ahead — slow down



Stop sign ahead



Roundabout ahead



Signal lights ahead



Signal lights ahead — prepare to stop when lights are flashing



Pedestrian crosswalk ahead



School crosswalk ahead
— this sign is fluorescent yellow-green



School bus stop ahead



Cyclists may be on roadway



Fire truck entrance ahead



Truck crossing ahead



Recommended exit speed — drive slower in poor conditions



Pavement ends ahead



Hazard or danger ahead
— turn right or left



Watch for deer ahead



Opening bridge ahead



Watch for rocks on the road ahead



Tunnel ahead



Remove sunglasses



Snow shed ahead



Use headlights ahead

Object markers

Pay special attention to object markers — they are mounted on obstructions.



Obstruction — keep right or left



Obstruction — keep right



Obstruction — keep left

Construction signs

These signs warn of construction and maintenance work. You must pay attention to the warnings and obey the instructions on these signs. Obey traffic-control persons, travel within the posted speed, stay well back from all equipment and pass only when it is safe.



Detour ahead



Soft shoulder ahead — stay off



Construction ahead



Traffic-control person ahead



Crew working — obey posted speed limit



Survey crew — obey posted speed limit



End of construction zone speed limit



Fine notice for speeding in a work zone



Blasting ahead — follow instructions on sign



Follow the lighted arrow

Information and destination signs

These signs give information about destinations, route numbers and facilities. Here are a few samples.



Destination sign — distances are in kilometres

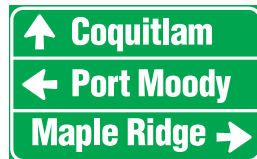

Directional sign



Trans-Canada Highway route marker



Primary highway marker sign



Hospital nearby



Gas available ahead



Accommodation ahead



Travel information ahead

Railway signs

Public railway and highway crossings are indicated with signs or pavement markings and may also have mechanical or electrical warning devices for your protection. Watch for them and remember you must always yield to trains.



Railway crossing ahead — be prepared to stop



Railway crossing on side road ahead — be prepared to stop

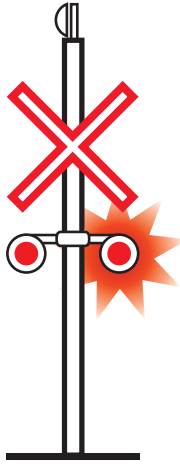

Railway crossing — stop, then proceed when it is safe

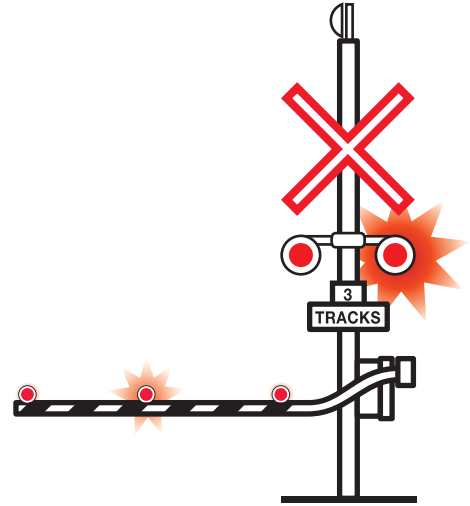

Railway crossing — stay stopped until the gate is fully raised

Signals

Lighted signals are a way of controlling traffic flow.

Lane control signals

Lane control signals are placed over lanes to indicate which ones are open for driving.



Do not drive in this lane



Move out of this lane and into a lane with a green arrow. If the lane control signals over all of the lanes are flashing yellow, slow down and proceed with caution



Drive in this lane

Traffic lights

Traffic lights are used to help organize the flow of traffic. Generally, a red light means “stop,” a yellow light means “caution” and a green light means “go.” These signals can have slightly different meanings if they are flashing or if they are shaped as arrows rather than circles. In some places green arrows may flash; in others they may not.

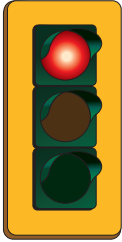

Steady red — stop — after coming to a full stop, you may turn right or turn left onto a one-way street unless a sign forbids it

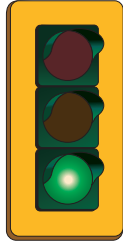

Steady green — continue if the intersection is clear

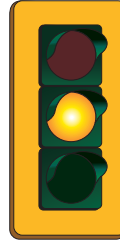

Steady yellow — slow down and stop before the intersection unless you can't safely stop in time

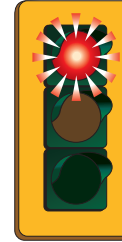

Flashing red — stop, then continue only when it is safe

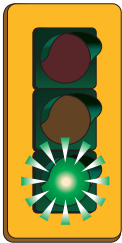

Flashing green — pedestrian-controlled light — go only if the intersection is clear



Flashing yellow — slow down and proceed with caution

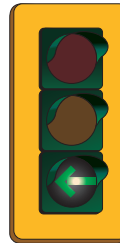

Green arrow — turn in the direction of the arrow

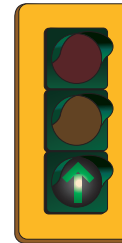

Green arrow — no turn permitted; go straight through only

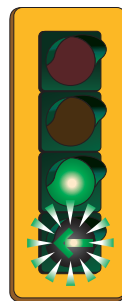

Flashing green arrow with a steady green light — may turn in the direction of the arrow or proceed

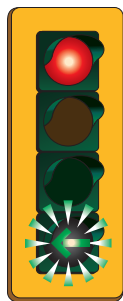

Flashing green arrow with a steady red light — left turn allowed; through traffic must stop for red light

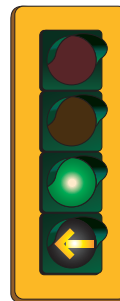

Yellow arrow — advance left turn signal is about to change, slow down and stop before the intersection unless you can't safely stop in time

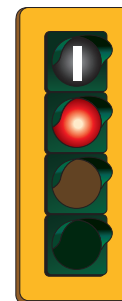

Transit priority signal — steady white rectangular light — only buses may go on this signal

Road markings

Road markings give you warnings or direction. They are painted on the roadway, curbs or other surfaces. It is illegal to drive over freshly painted, wet pavement markings.

Yellow lines

Yellow lines divide traffic moving in opposite directions. If there is a yellow line to your left, there will be traffic coming towards you on the other side of that yellow line.



Broken line — passing is allowed when safe



Broken line and solid line — you may pass only when it is safe and the broken line is on your side



Double solid line — no passing allowed



Single yellow line — passing is allowed with extra caution

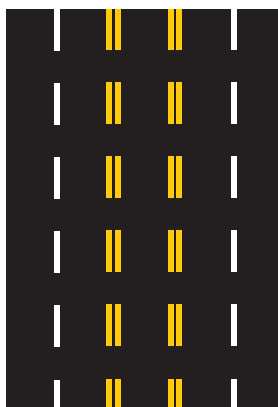

Double broken yellow line — lane is reversible — lane control signal will show whether you may use this lane

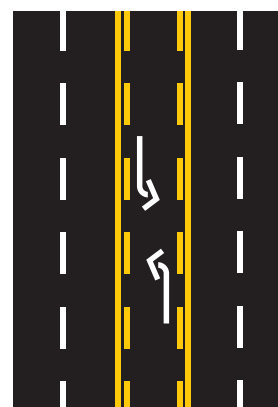

Two-way left-turn lane — drivers travelling in opposite directions share this lane for left turns — markings may be reversed (solid lines inside the broken lines)

White lines

White lines are used to separate lanes of traffic moving in the same direction. White lines also mark crosswalks, stopping positions and the right shoulders of highways.



Solid line — do not change lanes



Broken line — lane changing is allowed when safe



Stop line — stop before this line

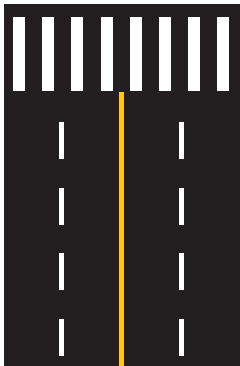

Pedestrian crosswalk — stop for pedestrians in the crosswalk



Pedestrian crosswalk — stop for pedestrians in the crosswalk

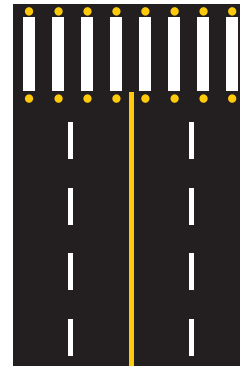

Pedestrian-activated crosswalk with illuminating lights in pavement — stop for pedestrians in the crosswalk

Reserved lane markings

These markings set off lanes for HOVs, buses and bicycles. HOV lanes are marked with thick solid or broken lines and white diamond symbols.

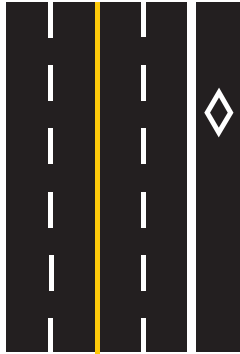

Reserved lane — additional signs or markings state which vehicles are allowed

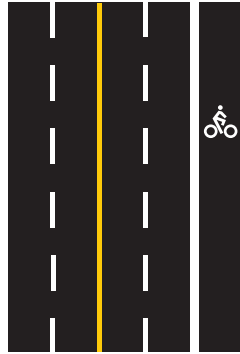

Bicycle lane — for cyclists only — cyclists must travel in the same direction as the traffic beside them — the lane is marked with an outline of a bicycle and sometimes with a diamond

Other markings



Vehicles in this lane must turn left

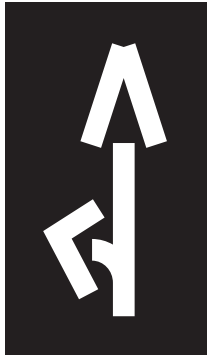

Vehicles in this lane must go straight or turn left

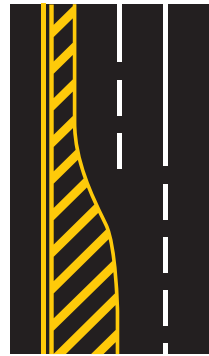

Painted island — keep to the right and do not drive on or over

summary

To safely operate an RV combination, you need a truck that is matched to the demands of your trailer, a trailer that is matched to your truck, and an appropriate coupler. You need to keep both the truck and trailer in safe operating condition, and conduct pre-trip inspections during your travels.

Make sure the trailer is securely fastened to the truck, the truck and trailer are level, and the weight is properly distributed.

Make sure your mirrors are properly adjusted.

Drive carefully and smoothly, avoiding abrupt steering changes or sudden changes in speed, and carefully maintain proper lane position.

Back up with care. Make sure it is clear before backing up and have someone assist by acting as your guide.

Always remember that a large RV trailer combination accelerates, turns and stops differently than a passenger car or pickup truck without a trailer. Look ahead and plan ahead for turns and other movements in traffic.

Review questions

1. What do you need to consider when selecting a vehicle to tow a recreational trailer?
2. How much of the trailer weight should be on the hitch?
3. What are the advantages of installing convex mirrors below the side mirrors?
4. How do you check that the fifth wheel jaws have locked to the trailer pin?
5. What is the advantage of doing a regular pre-trip vehicle inspection?
6. What safety equipment should you carry when towing an RV?
7. How does towing an RV affect braking and acceleration?
8. What should you do if your trailer whips or swerves?
9. Why is it important for you to know the height, width and weight of the truck and RV?
10. What can cause your trailer to jackknife when you are backing up?

Definitions

Gross Axle Weight Rating (GAWR) — the maximum weight that the manufacturer recommends placing over the axle. Front axles normally have a smaller GAWR than rear axles.

Gross Combined Weight Rating (GCWR) — the recommended maximum total weight of the tow vehicle and trailer including their loads.

Gross Vehicle Weight (GVW) — the weight of a vehicle and its load as it sits on the road.

Gross Vehicle Weight Rating (GVWR) — the maximum total weight of the vehicle and its load as recommended by the manufacturer.

Load capacity — the weight the vehicle or trailer can carry. It includes the weight of passengers, cargo, and in the case of the truck, the amount of the trailer weight over the truck.

Pin weight — the weight of the trailer that is over the truck. Pin weight is also known as kingpin weight or kingpin load.

Towing capacity — the weight that the truck is capable of towing.

Wheelbase — the distance between the front and rear axles.

More information

To report a claim, call Dial-a-Claim 24/7 at:

- 604-520-8222 (Lower Mainland)
- 1-800-910-4222 (elsewhere in B.C., Canada or U.S.)

If you've had a crash with no injuries, or want to report vandalism or theft from your vehicle, you can do that quickly and easily anytime online at icbc.com.

For general inquiries, call ICBC Customer Services at:

- 604-661-2800 (Lower Mainland)
- 1-800-663-3051 (elsewhere in B.C., Canada or U.S.)

Visit icbc.com or call 1-800-464-5050 for information on buying a used vehicle and to get a Vehicle Claims History Report.

Translation services available.

Identification (ID)

Every time you go to a driver licensing office, you'll need to take one piece of primary ID and one piece of secondary ID. Identification requirements are subject to change. Please see icbc.com/acceptedID for a current list of accepted ID.

Prepare for your tests!

If you do not qualify on the knowledge test you will need to wait seven days before another attempt can be made. For road tests, the re-test waiting period is 14 days after a first attempt, 30 days after a second attempt, and 60 days for any subsequent attempts.

New to B.C.?

Ensure you provide one primary and one secondary piece of ID and remember to bring your non-B.C. licence.

Has your name changed since birth?

Driver licences and B.C. Identification cards are issued in **legal name only**. If your name differs from that shown on your primary identification, you will also need to provide ALL name change documents to link back to your primary ID.

Photocopies are not accepted. The only exception is a photocopy that is certified as a true copy by the government agency that issued it.

One piece primary ID	
BC Driver's Licence (BCDL) (Must not be expired more than 3 years)	Canadian Passport (Must be valid and in exactly the same name as your Canadian Birth Certificate or Canadian Citizenship Certificate. If not, additional name linking document(s) will be required.)
BC Identification Card (BCID) (Must not be expired more than 3 years)	Canadian Record of Landing (Some exceptions apply)
BC Services Card with photo (Standalone or Combo) (Must not be expired more than 3 years)	Permanent Resident Card (Must not be expired)
Canadian Birth Certificate (Baptismal and Live Birth Certificates are not acceptable)	Student, Work, Visitor or Temporary-resident Permit (Form number is IMM1442) (Must not be expired)
Canadian Citizenship Card/Certificate (Commemorative certificates are not accepted)	
Indigenous Primary ID	
Certificate of Indian Status (Laser engraved photo cards with security features, issued by the Government of Canada) (White Card)	
One piece secondary ID	
Bank Card (Both your imprinted name and signature must appear on the card)	Health Card issued by other Canadian Province or Territory (Health Care Cards issued by AB not accepted as secondary)
BC Services Card Non Photo	Legal Name Change Certificate (Issued by Canadian Court or Canadian Provincial Vital Statistics Agency)
Birth Certificate from foreign country	Marriage Certificate (Issued by a vital statistic agency, religious organization or marriage commissioner)
Canadian Forces Identification	Nexus Card
Credit Card (Both your imprinted name and signature must appear on the card)	Passport (Foreign) (Must be valid and in exactly the same name as your Birth Certificate, Citizenship Cert., PRC or IMM. If not additional name linking document(s) will be required)
Department of National Defence 404 Licence	Canadian Passport (Must be valid and in exactly the same name as your Canadian Birth Certificate or Canadian Citizenship Certificate. If not, additional name linking document(s) will be required.)
Driver's Licence (Canadian or U.S.)	Police Identification Card
Employee ID Card (Must have name and photo)	Student Card or ID (Current year, name and photo must be imprinted)
Indigenous Secondary ID	
Certificate of Indian Status (Orange Laminated cards)	Métis Nation BC Citizenship and ID Card
Tla'amin Nation Citizenship Card	

A Combination BCDL/BCSC can only be used as one piece of ID.

Photocopies not accepted unless certified by issuing agency.

Legal Name Change or Marriage Certificate required when names do not match on your identification.

Identification requirements are subject to change. And as such this list is not exhaustive.

For updates and additional Secondary ID options please see icbc.com/acceptedID.

If you were born outside Canada and do not have any of the required primary identification documents, please contact Citizenship and Immigration Canada at 1-888-242-2100.

